

6LR & 6LM lines

Deepwell Borehole

Submersible multistage centrifugal pumps for 6" wells. Check valve built into the delivery outlet. Pump flange for coupling with motors are made according to NEMA standards. Most common applications are civil and agricultural. All components are made of stainless steel with lost wax Microfusion technology. The standard material is AISI 304 stainless steel, alternatively the following materials are available on request: AISI 316 Steel, Duplex steel. Bushing bearings and wear-rings made of sand abrasion-resistant rubber, reverse-Thrust ring in PTFE/Graphite.

General operating data:

- Capacity up to 90 m³/h
- Pressure up to 750 m
- Hydraulic efficiency 6", up to 78,5%
- Pressure up to 75 bar
- Powers up to 66 kW
- Rotation speed up to 2900 rpm
- Maximum depth: 350 m
- Maximum quantity of permitted sand: 100 gr/m³
- Drinking water compatibility according to DM174 MEI >= 0,4 (EU directive No.547/2012)
- Performance tolerance: ISO9906-3B

Construction features

Suction and delivery outlet	stainless steel AISI 304 (LRS-LMS) stainless steel AISI 316 (LRX-LMX) Duplex (LRD-LMD)
Valve	stainless steel AISI 304 (LRS-LMS) stainless steel AISI 316 (LRX-LMX) Duplex (LRD-LMD)
Impellers and diffusers	stainless steel AISI 304 (LRS-LMS) stainless steel AISI 316 (LRX-LMX) Duplex (LRD-LMD)
Upper bushings	NBR rubber
Shaft pump side	stainless steel AISI 304 (LRS-LMS) stainless steel AISI 316 (LRX-LMX) Duplex (LRD-LMD)
Quantity of sand in the water	max 100 g/m ³

Motor

Asynchronous 2 pole	rewindable water cooled
Insulation class	Y (max 30 °C) - PPC winding type F (max 50 °C) - PE2+PA or LPE winding type
Protection degree	IP68
Liquid temperature	max 30 °C (max 50 °C on request)
Depth of immersion	max 350 m



6LR line



6LM line



6LM 38

Motor 50 Hz - 2900 rpm				Q									
TYPE	Power		400 V	I/min	0	100	200	300	400	500	600	700	800
	HP	kW		A	I/sec	0	1,7	3,3	5,0	6,7	8,3	10,0	11,7
			m ³ /h		0	6	12	18	24	30	36	42	48
6LM 38/01	2	1,5	4,0	H[m]	14	14	13	13	12	11	10	9	7
6LM 38/02	4	3	7,5		29	27	26	25	24	23	20	17	14
6LM 38/03	5,5	4	10,0		43	41	39	38	36	34	31	26	20
6LM 38/04	7,5	5,5	12,5		57	55	52	51	48	45	41	35	27
6LM 38/05	10	7,5	16,3		71	69	65	64	60	56	51	44	34
6LM 38/06	12,5	9,2	19,9		86	82	78	76	72	68	61	52	41
6LM 38/07	15	11	23,4		100	96	91	89	84	79	71	61	48
6LM 38/08	15	11	23,4		114	110	104	102	96	90	81	70	55
6LM 38/09	17,5	13	27,3		129	123	117	114	108	102	92	78	61
6LM 38/10	20	15	31,5		143	137	130	127	120	113	102	87	68
6LM 38/11	20	15	31,5		157	151	143	140	132	124	112	96	75
6LM 38/12	25	18,5	38,3		172	164	156	152	144	136	122	104	82
6LM 38/13	25	18,5	38,3		186	178	169	165	156	147	132	113	89
6LM 38/14	30	22	45,1		200	192	182	178	168	158	143	122	95
6LM 38/15	30	22	45,1		214	206	195	191	180	169	153	131	102
6LM 38/16	30	22	45,1		229	219	208	203	192	181	163	139	109

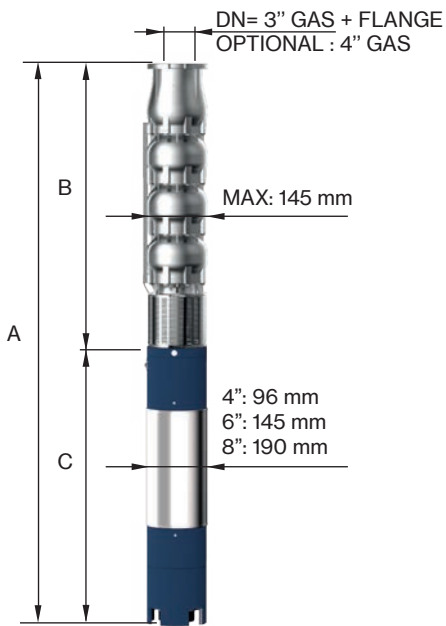

Motor 50 Hz 2900 rpm	DIMENSIONS (mm)			Weight (kg)	
	TYPE	A	B	C	M
6LM 38/01	746	354	392	13	8
6LM 38/02	1012	455	557	19	12
6LM 38/03	1153	556	597	22	15
6LM 38/04	1355	657	698	27	19
6LM 38/05	1499	798	701	55	23
6LM 38/06	1650	899	751	60	26
6LM 38/07	1811	1000	811	65	30
6LM 38/08	1912	1101	811	65	33
6LM 38/09	2043	1202	841	70	37
6LM 38/10	2234	1303	931	75	41
6LM 38/11	2335	1404	931	75	44
6LM 38/12	2496	1505	991	83	48
6LM 38/13	2597	1606	991	83	51
6LM 38/14	2778	1707	1071	92	55
6LM 38/15	2879	1808	1071	92	59
6LM 38/16	2980	1909	1071	92	62

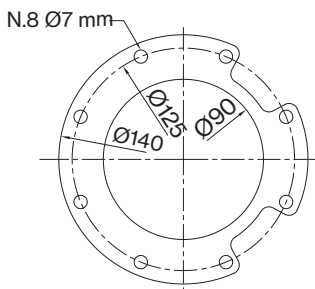

FOR COMMERCIAL TUBE
EXTERNAL DIAMETER: 88,9 mm

Max Eff. % =	76
Max kW / St. =	1,33

Q (flow)	25%	50%	75%	100%
NPSH (m)	3,4	3,4	3,8	8

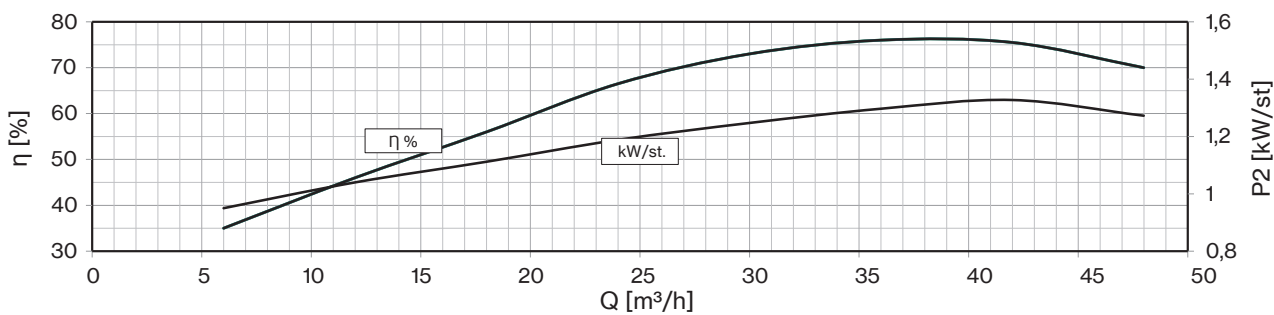
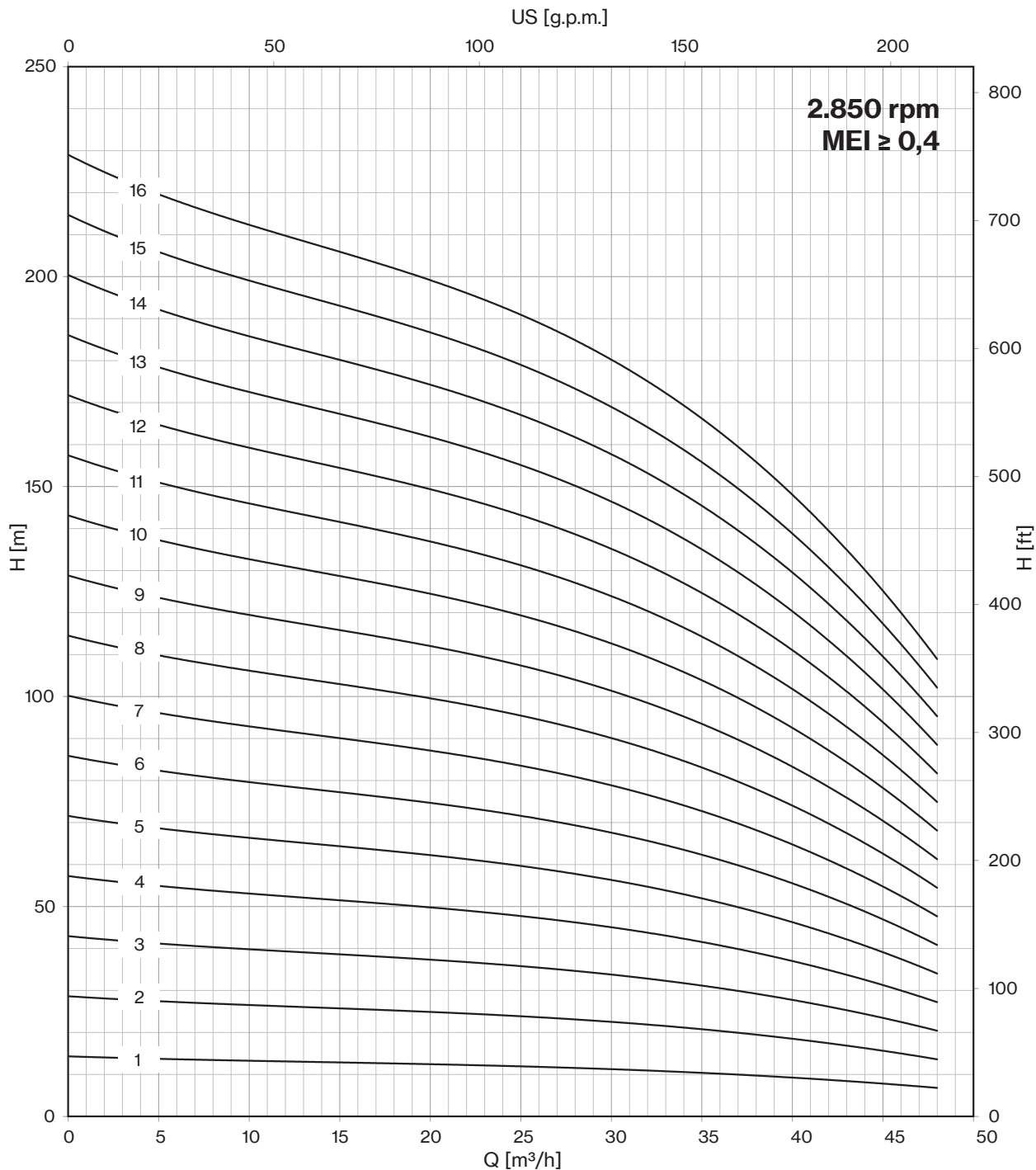

6LM 38

Motor 50 Hz - 2900 rpm				Q									
TYPE	Power		400 V	l/min l/sec m³/h	0	100	200	300	400	500	600	700	800
	HP	kW			A	0	1,7	3,3	5,0	6,7	8,3	10,0	11,7
					0	6	12	18	24	30	36	42	48
6LM 38/17	35	26	52,9	H[m]	243	233	221	216	204	192	173	148	116
6LM 38/18	35	26	52,9		257	247	234	229	216	203	183	157	123
6LM 38/19	35	26	52,9		272	260	247	241	228	215	194	165	129
6LM 38/20	40	30	61,1		286	274	260	254	240	226	204	174	136
6LM 38/21	40	30	61,1		300	288	273	267	252	237	214	183	143
6LM 38/22	40	30	61,1		315	301	286	279	264	249	224	191	150
6LM 38/23	50	37	75,8		329	315	299	292	276	260	234	200	157
6LM 38/24	50	37	75,8		343	329	312	305	288	271	244	209	164
6LM 38/25	50	37	75,8		357	343	325	318	300	282	255	218	170
6LM 38/26	50	37	75,8		372	356	338	330	312	294	265	226	177
6LM 38/27	50	37	75,8		386	370	351	343	324	305	275	235	184
6LM 38/28	60	45	86,3		400	384	364	356	336	316	285	244	191
6LM 38/29	60	45	86,3		415	397	377	368	348	328	295	252	198
6LM 38/30	60	45	86,3		429	411	390	381	360	339	306	261	204
6LM 38/31	60	45	86,3		443	425	403	394	372	350	316	270	211
6LM 38/32	60	45	86,3		457	438	416	407	384	361	326	279	218
6LM 38/33	60	45	86,3	472	452	429	419	396	373	336	287	225	

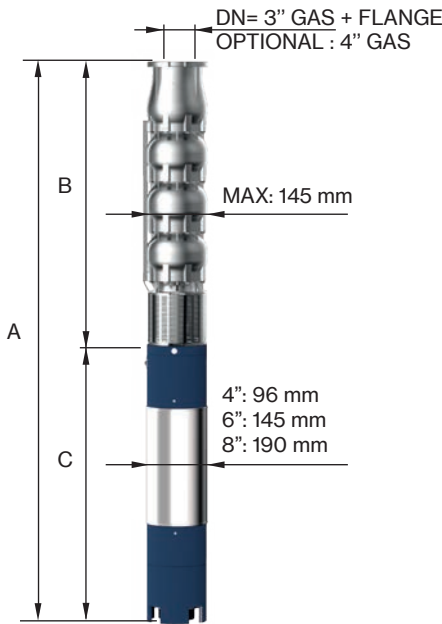

Motor 50 Hz 2900 rpm	DIMENSIONS (mm)			Weight (kg)	
	TYPE	A	B	C	M
6LM 38/17	3191	2010	1181	100	66
6LM 38/18	3292	2111	1181	100	69
6LM 38/19	3393	2212	1181	100	73
6LM 38/20	3564	2313	1251	108	77
6LM 38/21	3665	2414	1251	108	80
6LM 38/22	3766	2515	1251	108	84
6LM 38/23	3957	2616	1341	118	87
6LM 38/24	4058	2717	1341	118	91
6LM 38/25	4159	2818	1341	118	95
6LM 38/26	4260	2919	1341	118	98
6LM 38/27	4361	3020	1341	118	102
6LM 38/28	4311	3188	1123	178	109
6LM 38/29	4412	3289	1123	178	113
6LM 38/30	4513	3390	1123	178	116
6LM 38/31	4614	3491	1123	178	120
6LM 38/32	4715	3592	1123	178	124
6LM 38/33	4816	3693	1123	178	127

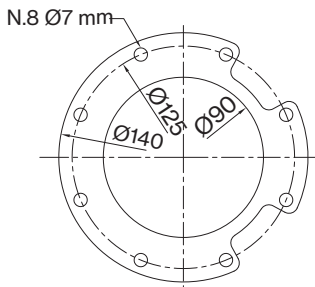

FOR COMMERCIAL TUBE
EXTERNAL DIAMETER: 88,9 mm

Max Eff. % =	76
Max kW / St. =	1,33

Q (flow)	25%	50%	75%	100%
NPSH (m)	3,4	3,4	3,8	8

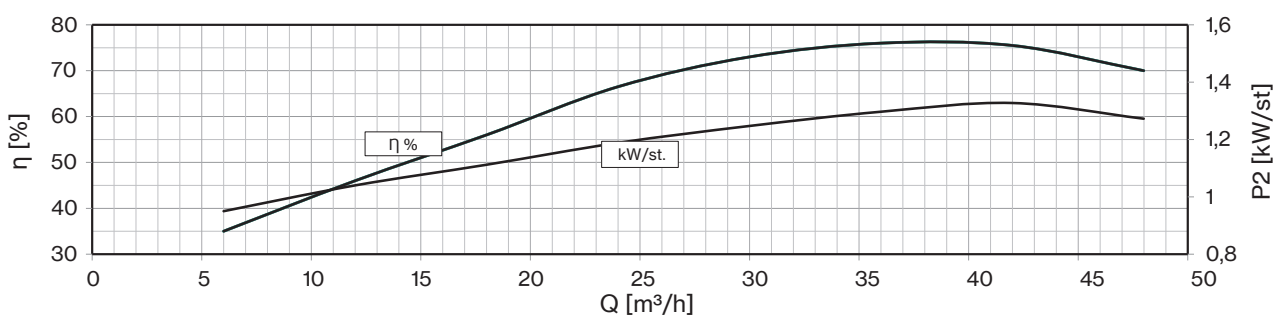
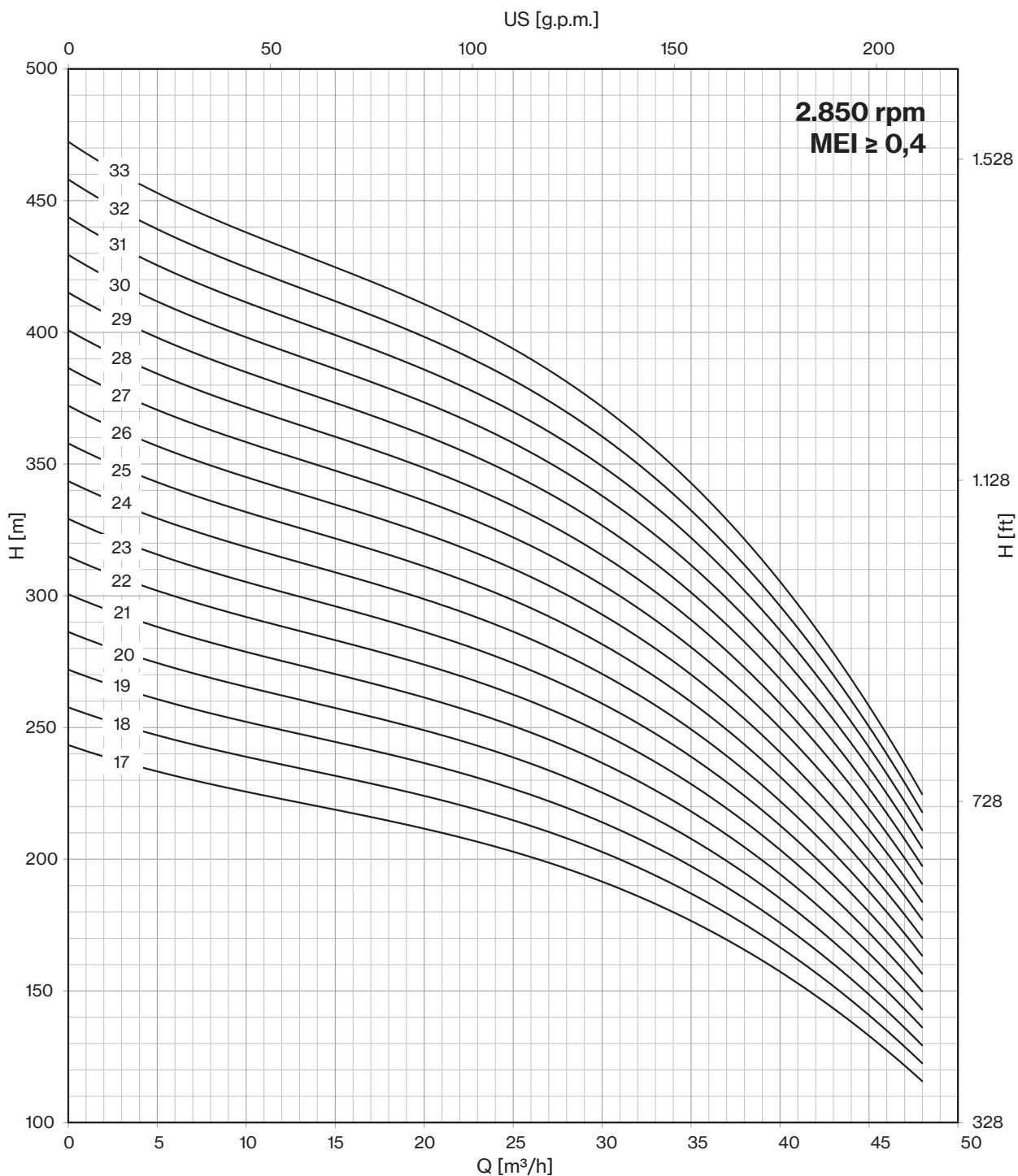

6LM 48

Motor 50 Hz - 2900 rpm				Q									
TYPE	Power		400 V	l/min l/sec m ³ /h	0	200	400	500	600	700	800	900	1000
	HP	kW			A	0	3,3	6,7	8,3	10,0	11,7	13,3	15,0
			H[m]										
6LM 48/01	2	1,5	4,0	14	14	11	11	11	10	9	7	6	
6LM 48/02	4	3	7,5	28	27	23	22	21	20	18	15	13	
6LM 48/03	7,5	5,5	12,5	42	41	34	33	32	29	26	22	19	
6LM 48/04	10	7,5	16,3	56	54	46	44	42	39	35	30	26	
6LM 48/05	10	7,5	16,3	70	68	57	56	53	49	44	37	32	
6LM 48/06	12,5	9,2	19,9	84	81	68	67	64	59	53	44	38	
6LM 48/07	15	11	23,4	98	95	80	78	74	69	62	52	45	
6LM 48/08	17,5	13	27,3	112	108	91	89	85	78	70	59	51	
6LM 48/09	17,5	13	27,3	126	122	103	100	95	88	79	67	58	
6LM 48/10	20	15	31,5	140	135	114	111	106	98	88	74	64	
6LM 48/11	25	18,5	38,3	154	149	125	122	117	108	97	81	70	
6LM 48/12	25	18,5	38,3	168	162	137	133	127	118	106	89	77	
6LM 48/13	30	22	45,1	182	176	148	144	138	127	114	96	83	
6LM 48/14	30	22	45,1	196	189	160	155	148	137	123	104	90	
6LM 48/15	30	22	45,1	210	203	171	167	159	147	132	111	96	
6LM 48/16	35	26	52,9	224	216	182	178	170	157	141	118	102	

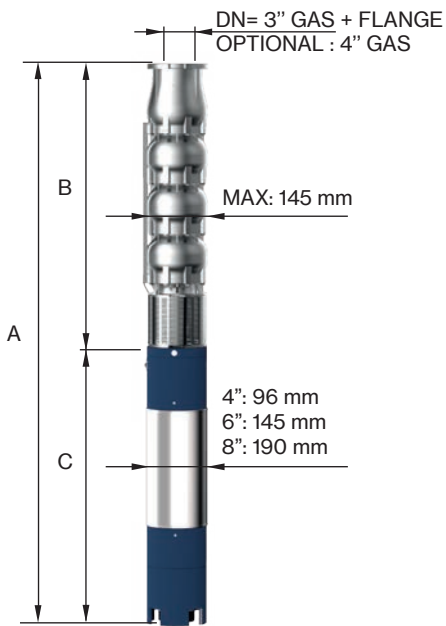

Motor 50 Hz 2900 rpm	DIMENSIONS (mm)			Weight (kg)	
	TYPE	A	B	C	M
6LM 48/01	746	354	392	13	8
6LM 48/02	1012	455	557	19	12
6LM 48/03	1254	556	698	27	15
6LM 48/04	1358	657	701	55	19
6LM 48/05	1499	798	701	55	23
6LM 48/06	1650	899	751	60	26
6LM 48/07	1811	1000	811	65	30
6LM 48/08	1942	1101	841	70	33
6LM 48/09	2043	1202	841	70	37
6LM 48/10	2234	1303	931	75	41
6LM 48/11	2395	1404	991	83	44
6LM 48/12	2496	1505	991	83	48
6LM 48/13	2677	1606	1071	92	51
6LM 48/14	2778	1707	1071	92	55
6LM 48/15	2879	1808	1071	92	59
6LM 48/16	3090	1909	1181	100	62

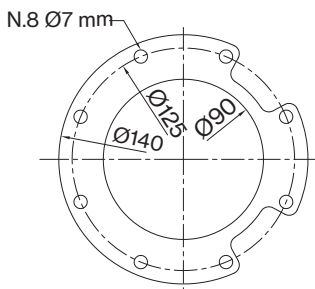

FOR COMMERCIAL TUBE
EXTERNAL DIAMETER: 88,9 mm

Max Eff. % =	78,5
Max kW / St. =	1,44

Q (flow)	25%	50%	75%	100%
NPSH (m)	3,45	3,5	3,8	5

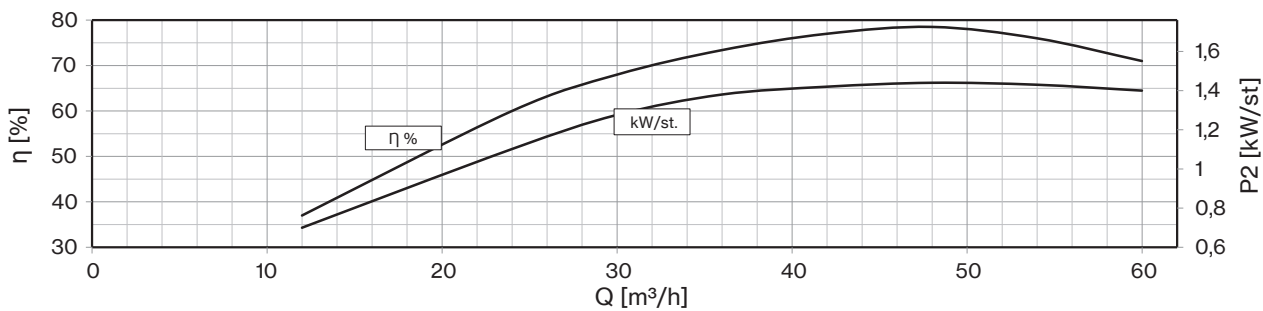
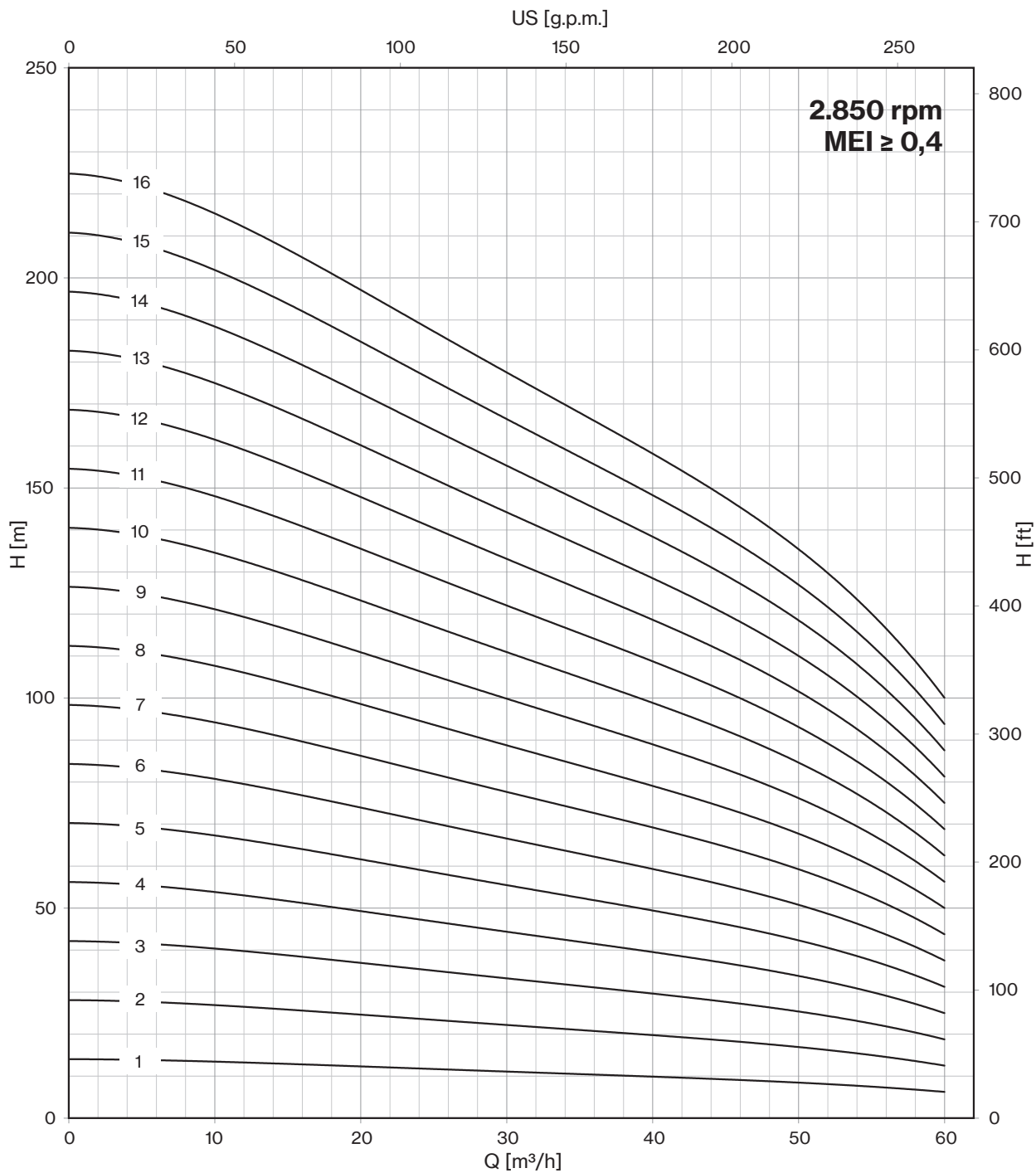

6LM 48

Motor 50 Hz - 2900 rpm				Q									
TYPE	Power		400 V	l/min l/sec m ³ /h	0	200	400	500	600	700	800	900	1000
	HP	kW			0	3,3	6,7	8,3	10,0	11,7	13,3	15,0	16,7
	A		0	12	24	30	36	42	48	54	60		
6LM 48/17	35	26	52,9	H[m]	238	230	194	189	180	167	150	126	109
6LM 48/18	35	26	52,9		252	243	205	200	191	176	158	133	115
6LM 48/19	40	30	61,1		266	257	217	211	201	186	167	141	122
6LM 48/20	40	30	61,1		280	270	228	222	212	196	176	148	128
6LM 48/21	50	37	75,8		294	284	239	233	223	206	185	155	134
6LM 48/22	50	37	75,8		308	297	251	244	233	216	194	163	141
6LM 48/23	50	37	75,8		322	311	262	255	244	225	202	170	147
6LM 48/24	50	37	75,8		336	324	274	266	254	235	211	178	154
6LM 48/25	50	37	75,8		350	338	285	278	265	245	220	185	160
6LM 48/26	60	45	86,3		364	351	296	289	276	255	229	192	166
6LM 48/27	60	45	86,3		378	365	308	300	286	265	238	200	173
6LM 48/28	60	45	86,3		392	378	319	311	297	274	246	207	179
6LM 48/29	60	45	86,3		406	392	331	322	307	284	255	215	186
6LM 48/30	60	45	86,3		420	405	342	333	318	294	264	222	192

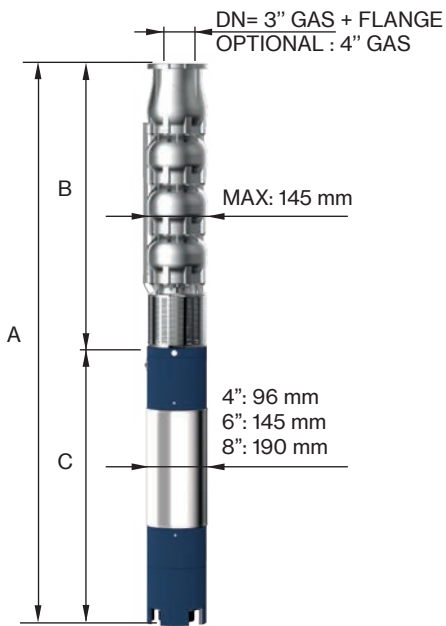

Motor 50 Hz 2900 rpm	DIMENSIONS (mm)			Weight (kg)	
	TYPE	A	B	C	M
6LM 48/17	3191	2010	1181	100	66
6LM 48/18	3292	2111	1181	100	69
6LM 48/19	3463	2212	1251	108	73
6LM 48/20	3564	2313	1251	108	77
6LM 48/21	3755	2414	1341	118	80
6LM 48/22	3856	2515	1341	118	84
6LM 48/23	3957	2616	1341	118	87
6LM 48/24	4058	2717	1341	118	91
6LM 48/25	4159	2818	1341	118	95
6LM 48/26	4109	2986	1123	178	102
6LM 48/27	4210	3087	1123	178	106
6LM 48/28	4311	3188	1123	178	109
6LM 48/29	4412	3289	1123	178	113
6LM 48/30	4513	3390	1123	178	116

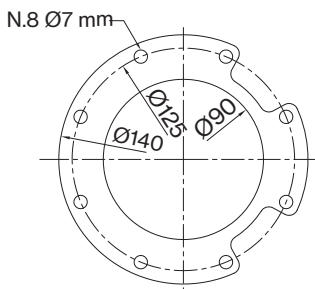

FOR COMMERCIAL TUBE
EXTERNAL DIAMETER: 88,9 mm

Max Eff. % =	78,5
Max kW / St. =	1,44

Q (flow)	25%	50%	75%	100%
NPSH (m)	3,45	3,5	3,8	5

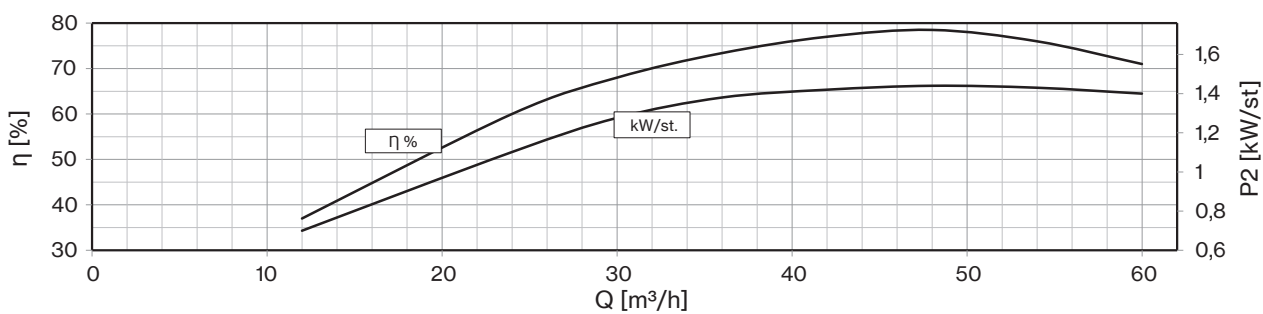
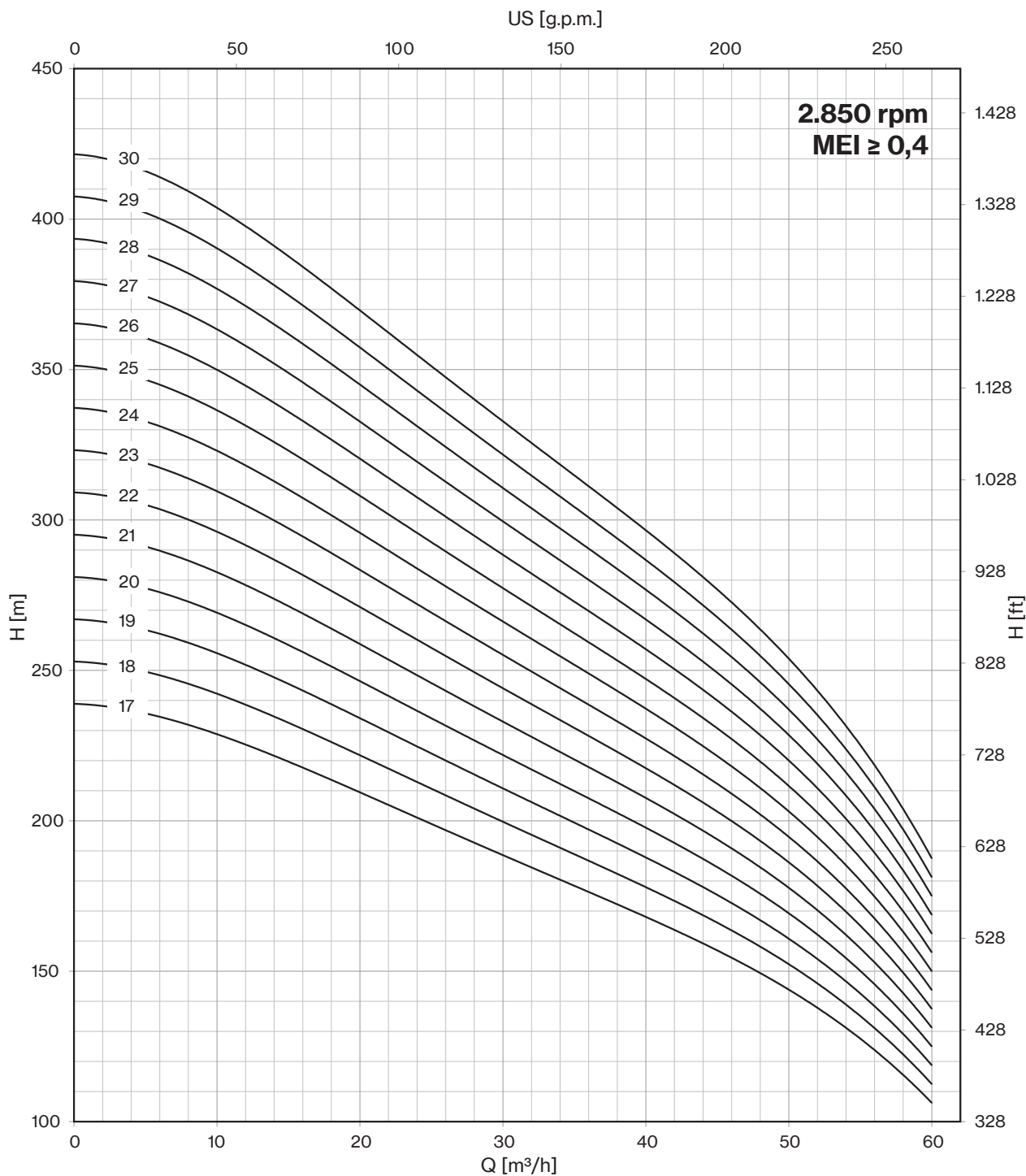

6LM 60

Motor 50 Hz - 2900 rpm				Q									
TYPE	Power		400 V	I/min	0	300	600	700	800	900	1000	1100	1200
	HP	kW	A	I/sec	0	5,0	10,0	11,7	13,3	15,0	16,7	18,3	20,0
				m ³ /h	0	18	36	42	48	54	60	66	72
6LM 60/01	3	2	5,50	H[m]	14	12	10	10	9	9	8	7	6
6LM 60/02	5,5	4	10,00		27	25	21	19	18	17	16	14	12
6LM 60/03	7,5	5,5	12,50		41	37	31	29	27	26	23	21	18
6LM 60/04	10	7,5	16,30		55	49	41	38	36	34	31	28	24
6LM 60/05	12,5	9,2	19,90		69	62	52	48	46	43	39	35	30
6LM 60/06	15	11	23,40		82	74	62	58	55	51	47	41	36
6LM 60/07	17,5	13	27,30		96	86	72	67	64	60	55	48	42
6LM 60/08	20	15	31,50		110	98	82	77	73	68	62	55	48
6LM 60/09	20	15	31,50		123	111	93	86	82	77	70	62	54
6LM 60/10	25	18,5	38,30		137	123	103	96	91	85	78	69	60
6LM 60/11	25	18,5	38,30		151	135	113	106	100	94	86	76	66
6LM 60/12	30	22	45,10		164	148	124	115	109	102	94	83	72
6LM 60/13	30	22	45,10		178	160	134	125	118	111	101	90	78
6LM 60/14	35	26	52,90		192	172	144	134	127	119	109	97	84
6LM 60/15	35	26	52,90		206	185	155	144	137	128	117	104	90
6LM 60/16	40	30	61,10		219	197	165	154	146	136	125	110	96

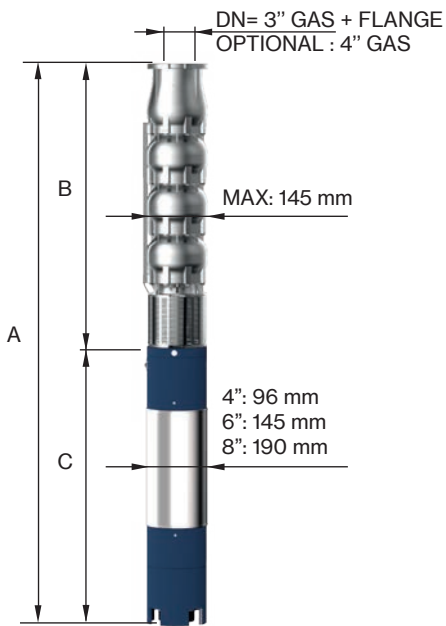

Motor 50 Hz 2900 rpm	DIMENSIONS (mm)			Weight (kg)	
	TYPE	A	B	C	M
6LM 60/01	812	360	452	15	8
6LM 60/02	1064	467	597	22	12
6LM 60/03	1272	574	698	27	16
6LM 60/04	1422	721	701	55	20
6LM 60/05	1579	828	751	60	24
6LM 60/06	1746	935	811	65	27
6LM 60/07	1883	1042	841	70	31
6LM 60/08	2080	1149	931	75	35
6LM 60/09	2187	1256	931	75	39
6LM 60/10	2354	1363	991	83	43
6LM 60/11	2461	1470	991	83	46
6LM 60/12	2648	1577	1071	92	50
6LM 60/13	2755	1684	1071	92	54
6LM 60/14	2972	1791	1181	100	58
6LM 60/15	3079	1898	1181	100	62
6LM 60/16	3256	2005	1251	108	65

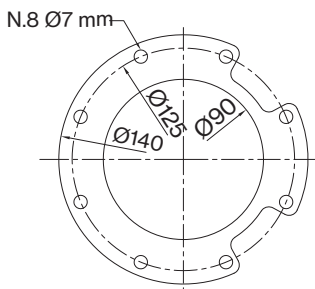

FOR COMMERCIAL TUBE
EXTERNAL DIAMETER: 88,9 mm

Max Eff. % =	77
Max kW / St. =	1,65

Q (flow)	25%	50%	75%	100%
NPSH (m)	3,8	3,8	5,1	7,1

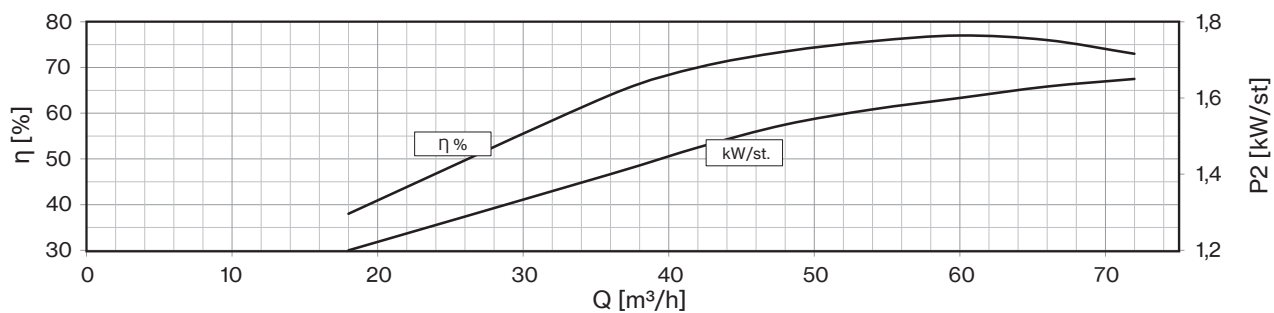
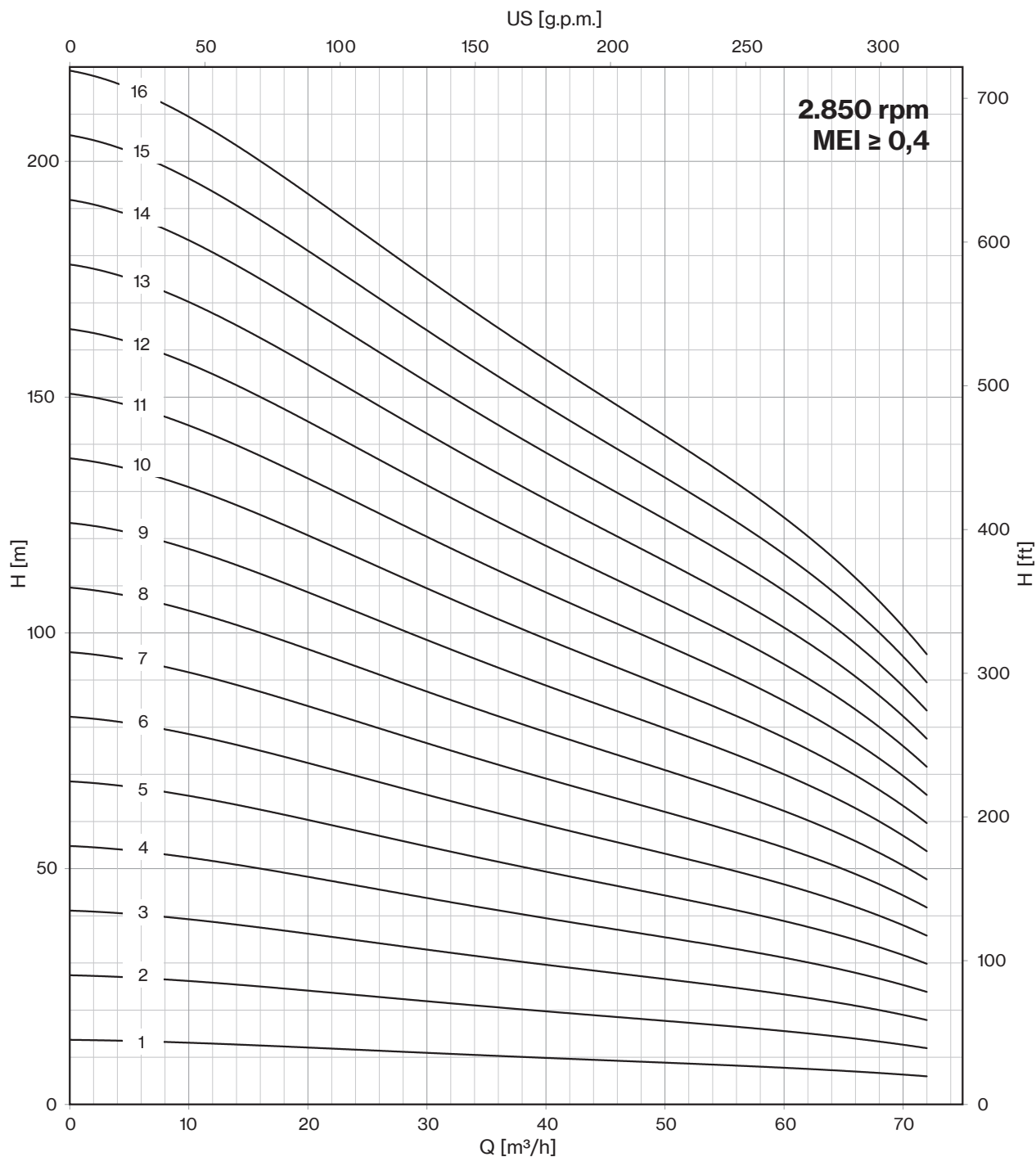

6LM 60

Motor 50 Hz - 2900 rpm				Q									
TYPE	Power		400 V	l/min l/sec m³/h	0	300	600	700	800	900	1000	1100	1200
	HP	kW			0	5,0	10,0	11,7	13,3	15,0	16,7	18,3	20,0
	A		0	18	36	42	48	54	60	66	72		
6LM 60/17	40	30	61,1	H[m]	233	209	175	163	155	145	133	117	102
6LM 60/18	40	30	61,1		247	221	185	173	164	153	140	124	108
6LM 60/19	50	37	75,8		260	234	196	182	173	162	148	131	114
6LM 60/20	50	37	75,8		274	246	206	192	182	170	156	138	120
6LM 60/21	50	37	75,8		288	258	216	202	191	179	164	145	126
6LM 60/22	50	37	75,8		301	271	227	211	200	187	172	152	132
6LM 60/23	60	45	86,3		315	283	237	221	209	196	179	159	138
6LM 60/24	60	45	86,3		329	295	247	230	218	204	187	166	144
6LM 60/25	60	45	86,3		343	308	258	240	228	213	195	173	150
6LM 60/26	60	45	86,3		356	320	268	250	237	221	203	179	156
6LM 60/27	60	45	86,3		370	332	278	259	246	230	211	186	162
6LM 60/28	75	55	106,2		384	344	288	269	255	238	218	193	168
6LM 60/29	75	55	106,2		397	357	299	278	264	247	226	200	174
6LM 60/30	75	55	106,2		411	369	309	288	273	255	234	207	180
6LM 60/31	75	55	106,2		425	381	319	298	282	264	242	214	186
6LM 60/32	75	55	106,2		438	394	330	307	291	272	250	221	192
6LM 60/33	75	55	106,2	452	406	340	317	300	281	257	228	198	

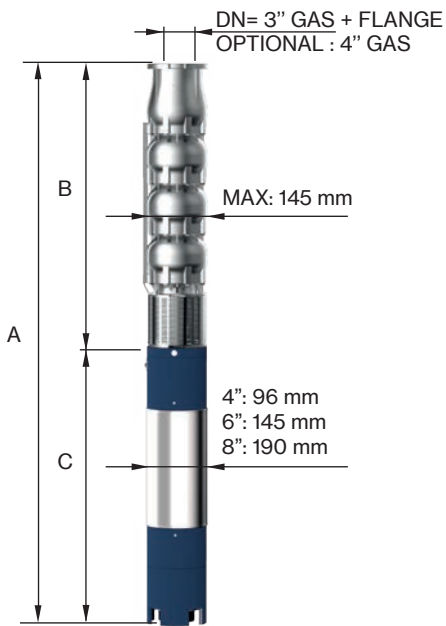

Motor 50 Hz 2900 rpm	DIMENSIONS (mm)			Weight (kg)	
	TYPE	A	B	C	M
6LM 60/17	3363	2112	1251	108	69
6LM 60/18	3470	2219	1251	108	73
6LM 60/19	3667	2326	1341	118	77
6LM 60/20	3774	2433	1341	118	81
6LM 60/21	3881	2540	1341	118	84
6LM 60/22	3988	2647	1341	118	88
6LM 60/23	3944	2821	1123	178	96
6LM 60/24	4051	2928	1123	178	100
6LM 60/25	4158	3035	1123	178	103
6LM 60/26	4265	3142	1123	178	107
6LM 60/27	4372	3249	1123	178	111
6LM 60/28	4589	3356	1233	200	115
6LM 60/29	4696	3463	1233	200	119
6LM 60/30	4803	3570	1233	200	122
6LM 60/31	4910	3677	1233	200	126
6LM 60/32	5017	3784	1233	200	130
6LM 60/33	5124	3891	1233	200	134

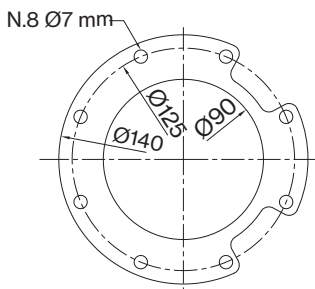

FOR COMMERCIAL TUBE
EXTERNAL DIAMETER: 88,9 mm

Max Eff. % =	77
Max kW / St. =	1,65

Q (flow)	25%	50%	75%	100%
NPSH (m)	3,8	3,8	5,1	7,1

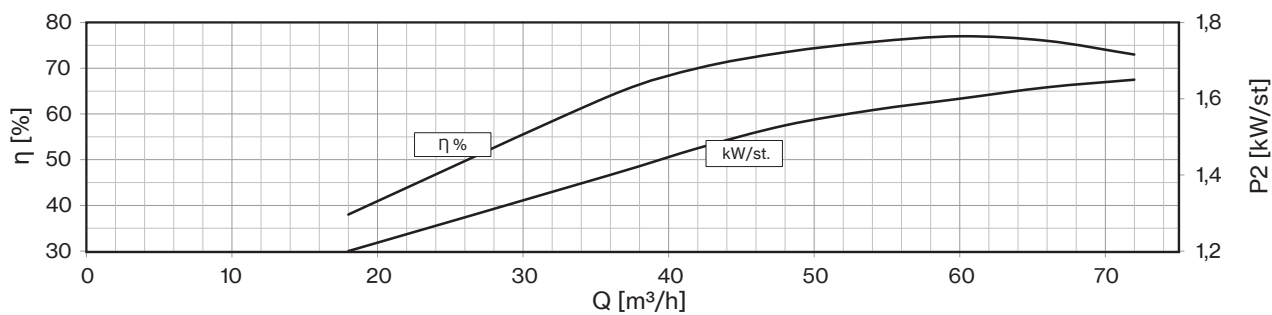
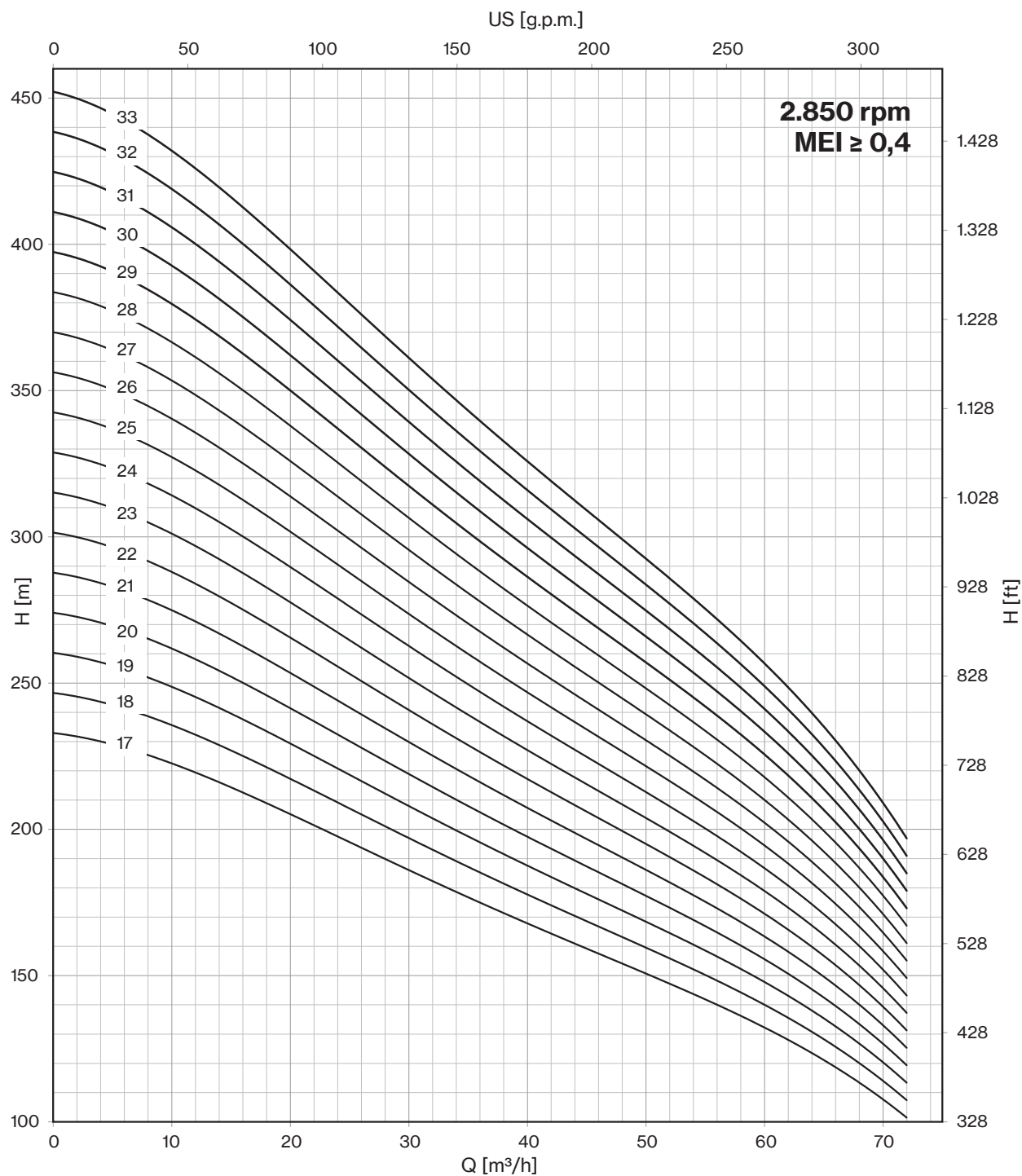

6LM 70

Motor 50 Hz - 2900 rpm				Q									
TYPE	Power		400 V	l/min l/sec m ³ /h	0	300	900	1000	1100	1200	1300	1400	1500
	HP	kW			0	5,0	15,0	16,7	18,3	20,0	21,7	23,3	25,0
	A		0	18	54	60	66	72	78	84	90		
6LM 70/01	3	2,2	5,5	H[m]	13	12	10	9	9	9	8	7	6
6LM 70/02	7,5	5,5	12,5		26	24	19	19	18	17	15	13	11
6LM 70/03	10	7,5	16,3		39	36	29	28	27	26	23	20	17
6LM 70/04	12,5	9,2	19,9		52	48	38	38	36	34	30	26	22
6LM 70/05	15	11	23,4		66	61	48	47	46	43	38	33	28
6LM 70/06	20	15	31,5		79	73	57	56	55	51	46	40	34
6LM 70/07	25	18,5	38,3		92	85	67	66	64	60	53	46	39
6LM 70/08	25	18,5	38,3		105	97	76	75	73	68	61	53	45
6LM 70/09	30	22	45,1		118	109	86	85	82	77	68	59	50
6LM 70/10	30	22	45,1		131	121	96	94	91	85	76	66	56
6LM 70/11	35	26	52,9		144	133	105	103	100	94	84	73	62
6LM 70/12	40	30	61,1		157	145	115	113	109	102	91	79	67
6LM 70/13	40	30	61,1		170	157	124	122	118	111	99	86	73

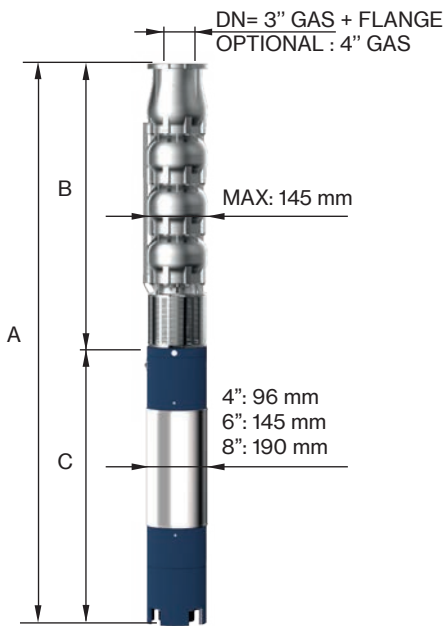

Motor 50 Hz 2900 rpm	DIMENSIONS (mm)			Weight (kg)	
	TYPE	A	B	C	M
6LM 70/01	812	360	452	15	8
6LM 70/02	1165	467	698	27	12
6LM 70/03	1315	614	701	55	16
6LM 70/04	1472	721	751	60	20
6LM 70/05	1639	828	811	65	24
6LM 70/06	1866	935	931	75	27
6LM 70/07	2033	1042	991	83	31
6LM 70/08	2140	1149	991	83	35
6LM 70/09	2327	1256	1071	92	39
6LM 70/10	2434	1363	1071	92	43
6LM 70/11	2651	1470	1181	100	46
6LM 70/12	2828	1577	1251	108	50
6LM 70/13	2935	1684	1251	108	54

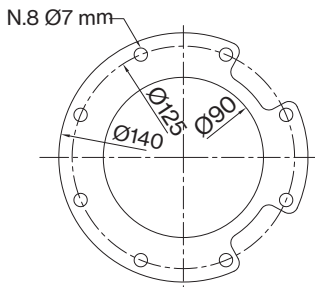

FOR COMMERCIAL TUBE
EXTERNAL DIAMETER: 88,9 mm

Max Eff. % =	76
Max kW / St. =	2,8

Q (flow)	25%	50%	75%	100%
NPSH (m)	3,8	3,8	5,1	7,1

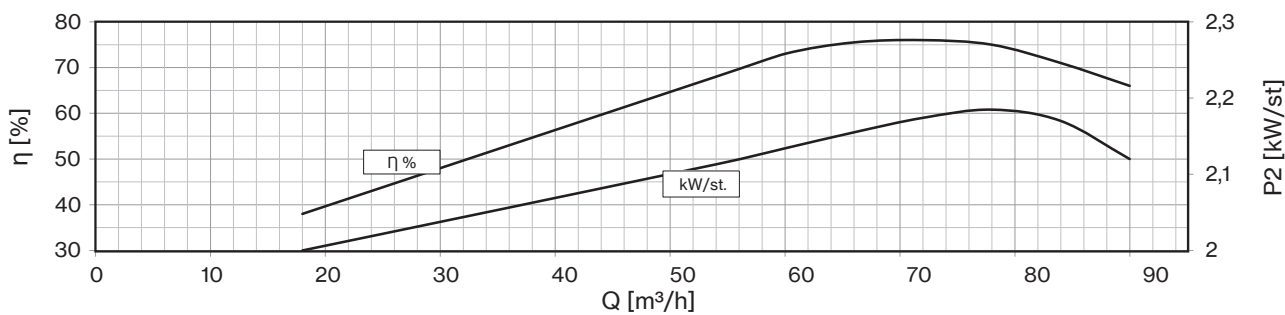
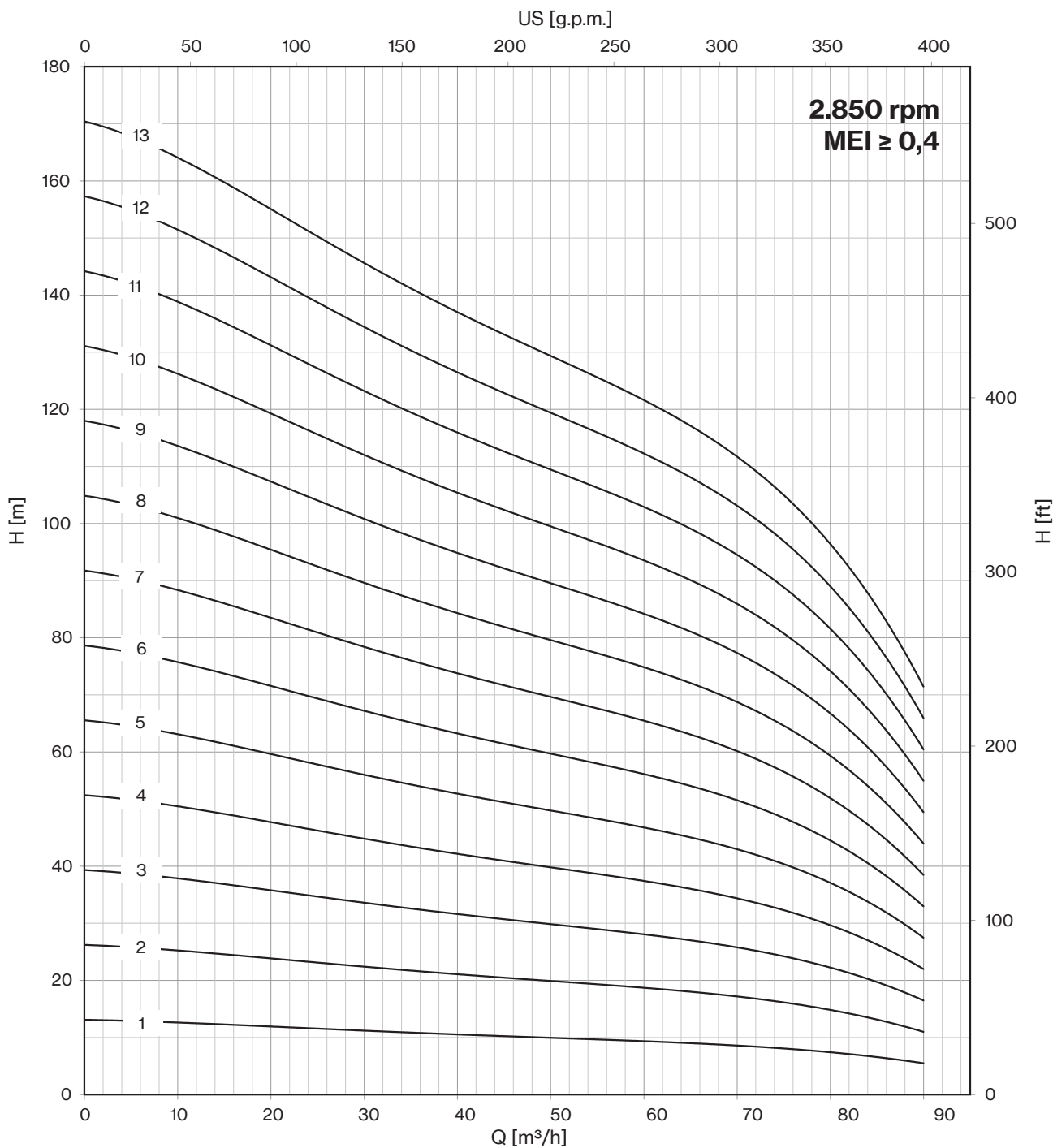

6LM 70

Motor 50 Hz - 2900 rpm				Q									
TYPE	Power		400 V	l/min l/sec m ³ /h	0	300	900	1000	1100	1200	1300	1400	1500
	HP	kW			0	5,0	15,0	16,7	18,3	20,0	21,7	23,3	25,0
	A		0	18	54	60	66	72	78	84	90		
6LM 70/14	50	37	75,8	H[m]	183	169	134	132	127	119	106	92	78
6LM 70/15	50	37	75,8		197	182	143	141	137	128	114	99	84
6LM 70/16	50	37	75,8		210	194	153	150	146	136	122	106	90
6LM 70/17	60	45	86,3		223	206	162	160	155	145	129	112	95
6LM 70/18	60	45	86,3		236	218	172	169	164	153	137	119	101
6LM 70/19	60	45	86,3		249	230	181	179	173	162	144	125	106
6LM 70/20	60	45	86,3		262	242	191	188	182	170	152	132	112
6LM 70/21	75	55	106,2		275	254	201	197	191	179	160	139	118
6LM 70/22	75	55	106,2		288	266	210	207	200	187	167	145	123
6LM 70/23	75	55	106,2		301	278	220	216	209	196	175	152	129
6LM 70/24	75	55	106,2		314	290	229	226	218	204	182	158	134
6LM 70/25	75	55	106,2		328	303	239	235	228	213	190	165	140

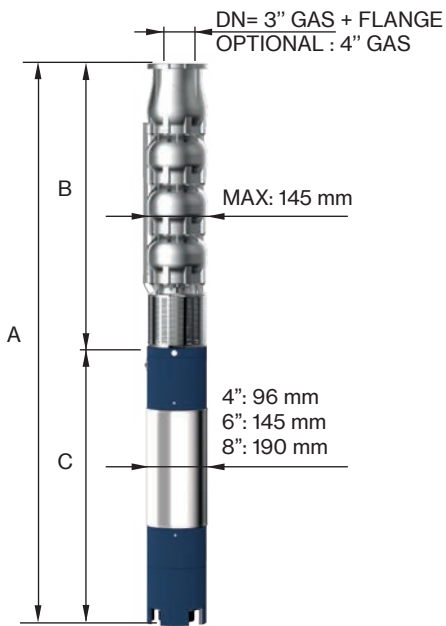

Motor 50 Hz 2900 rpm	DIMENSIONS (mm)			Weight (kg)	
	TYPE	A	B	C	M
6LM 70/14	3132	1791	1341	118	58
6LM 70/15	3239	1898	1341	118	62
6LM 70/16	3346	2005	1341	118	65
6LM 70/17	3235	2112	1123	178	69
6LM 70/18	3342	2219	1123	178	73
6LM 70/19	3516	2393	1123	178	81
6LM 70/20	3623	2500	1123	178	84
6LM 70/21	3840	2607	1233	200	88
6LM 70/22	3947	2714	1233	200	92
6LM 70/23	4054	2821	1233	200	96
6LM 70/24	4161	2928	1233	200	100
6LM 70/25	4268	3035	1233	200	103

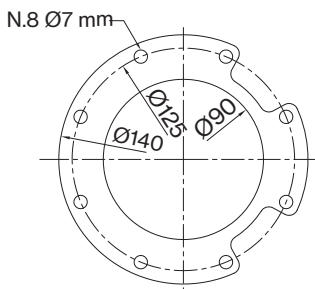

FOR COMMERCIAL TUBE
EXTERNAL DIAMETER: 88,9 mm

Max Eff. % =	76
Max kW / St. =	2,8

Q (flow)	25%	50%	75%	100%
NPSH (m)	3,8	3,8	5,1	7,1

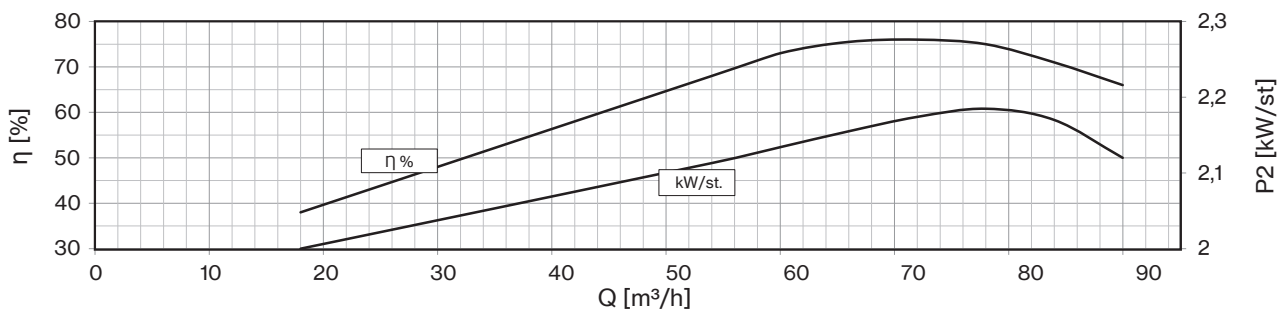
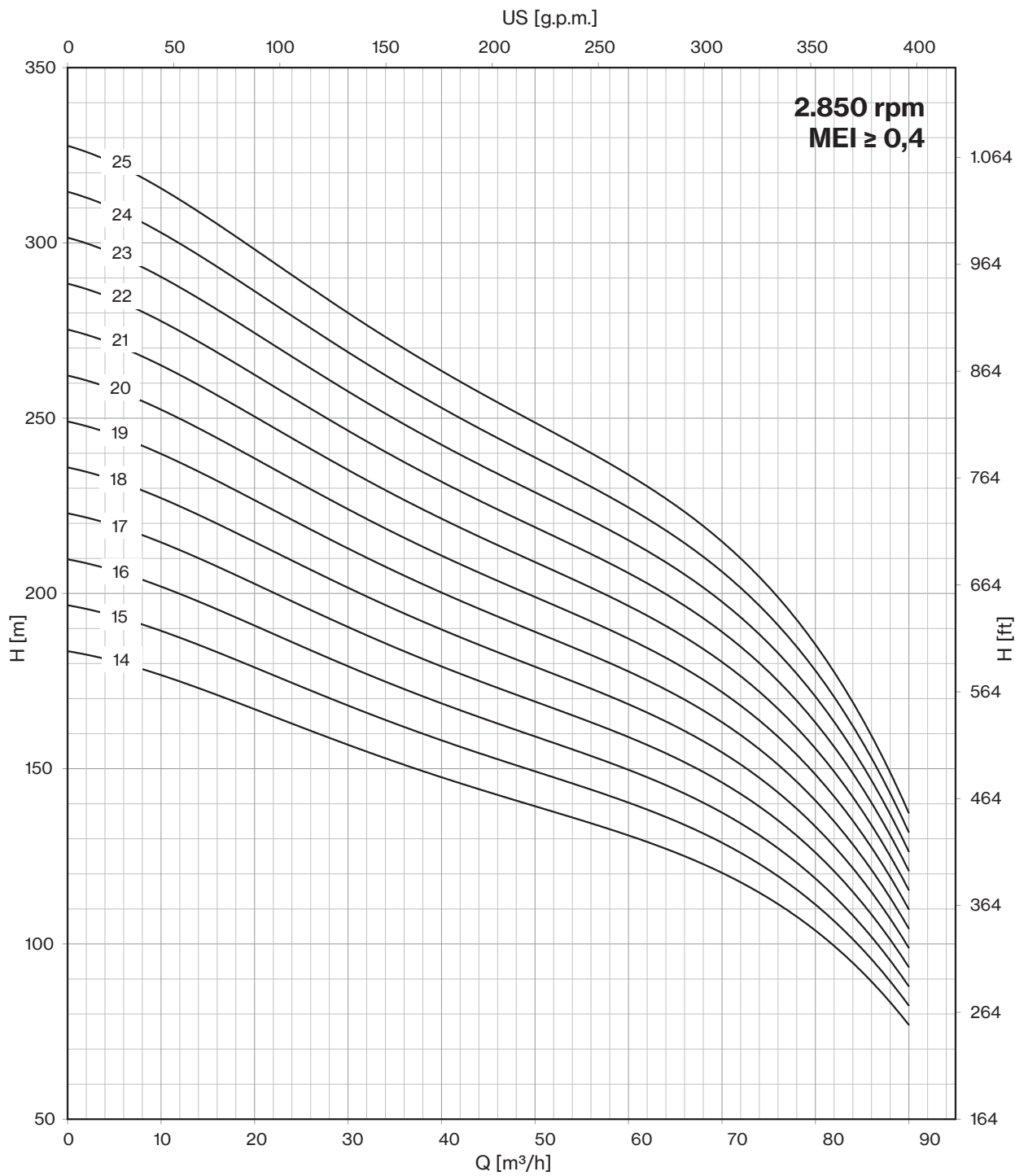

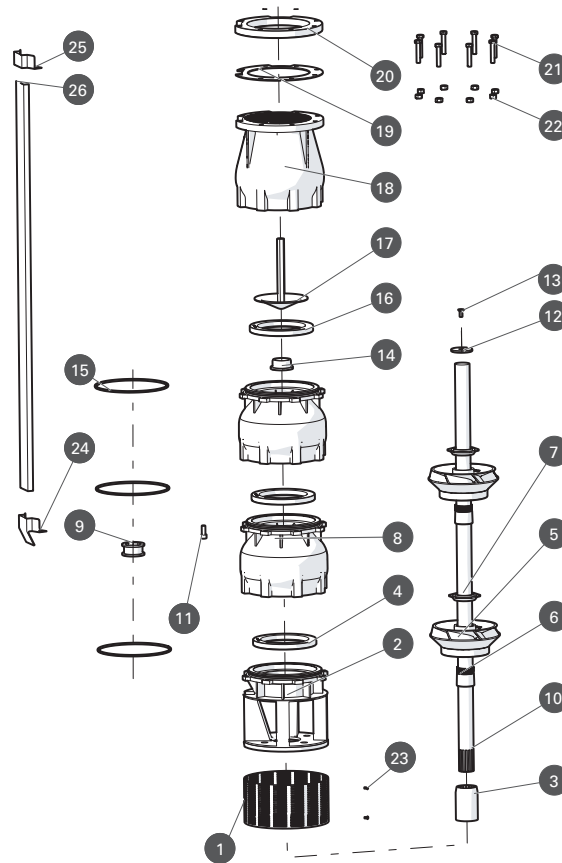

N° CODE	DESCRIPTION	LMS EXECUTION	LMX EXECUTION	LMD EXECUTION	(*) Q.TY
1	Suction strainer	AISI 304	AISI 316	Duplex	-
2	Suction cage	AISI 304	AISI 316	Duplex	-
3	Joint	AISI 304	AISI 316	Duplex	1
4	Usury ring	NBR	NBR	NBR	N° of St.
5	Impeller	AISI 304	AISI 316	Duplex	-
6	Cone	AISI 304	AISI 316	Duplex	N° of St.
7	Hexagonal ring	AISI 304	AISI 316	Duplex	N° of St.
8	Diffuseur	AISI 304	AISI 316	Duplex	-
9	Bearing bush	NBR	NBR	NBR	N° of St.
10	Pump shaft	AISI 304	AISI 316	Duplex	1
11	N.8 Screw for diffuseur	AISI 304	AISI 316	Duplex	-
12	Ring	AISI 304	AISI 316	Duplex	1
13	Screw for disk	AISI 304	AISI 316	Duplex	1
14	Counterthrust	PTFE + 25% CARBON	PTFE + 25% CARBON	PTFE + 25% CARBON	1
15	O-Ring	NBR	NBR	NBR	N° of St.
16	Gasket valve	NBR	NBR	NBR	1
17	Cap valve	AISI 304	AISI 316	Duplex	-
18	Body valve	AISI 304	AISI 316	Duplex	-
19	Seal counterflange	NBR	NBR	NBR	1
20	Counterflange	AISI 304	AISI 316	Duplex	-
21	N.8 Screw for counterflange	AISI 304	AISI 316	Duplex	-
22	N.8 Nut for counterflange	AISI 304	AISI 316	Duplex	-
23	N.2 Screw for suction strainer	AISI 304	AISI 316	Duplex	-
24	Lower clamp	AISI 304	AISI 316	Duplex	-
25	Upper clamp	AISI 304	AISI 316	Duplex	-
26	Cover cable	AISI 304	AISI 316	Duplex	-

* Recommended spare parts quantity