

## Construction features

**Pump body** cast iron



**Impeller** cast iron

### Mechanical seal

double seal with oil barrier; silicon carbide on pump side, ceramic-graphite on motor side

**Motor shaft** stainless steel AISI 304

**Free passage** Ø max 50 mm

**Max submergence** 20 m

**Liquid temperature** 0 - 40 °C

**Cable** H07 RN8F, 10 m

**Bolts** A2 stainless steel

**Foot support** galvanized iron

**Gaskets** NBR rubber

## Motor

### 4 Poles induction motor

3- 230V-50Hz  
3- 400V-50Hz  
3- 230/400V-50Hz  
3- 400/690V-50Hz

**Insulation class** F

**Protection degree** IPX8

TYPE	LOTS			
	TRUCK		CONTAINER	
	PALLET (cm)	N° pumps	PALLET (cm)	N° pumps
FV 250-4/750-4 T	85×110×190	8	100×120×190	12



# FV4

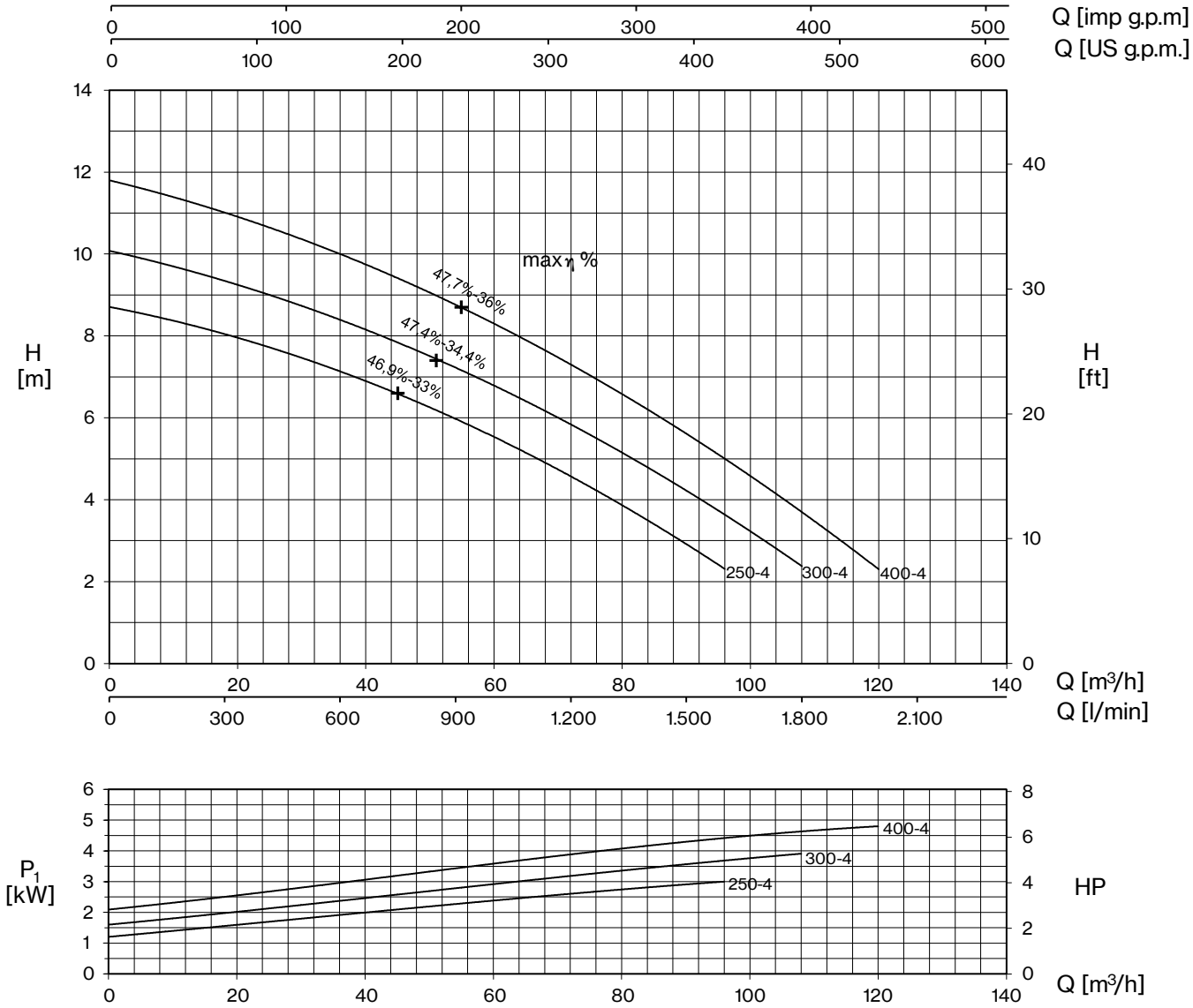

TYPE	AMPERE			
	3x230 V 50 Hz (*)	3x400 V 50 Hz	230/400 V 50 Hz λ / Δ (*)	400/690 V 50 Hz λ / Δ
FV 250-4 T	10,0	5,8	-	-
FV 300-4 T	11,8	6,8	-	-
FV 400-4 T	15,1	8,7	-	-

**+ max η %**  
max hydraulic efficiency and respective total efficiency

(\*) no standard execution

TYPE	P2		P1 (kW)	Q (m³/h - l/min)											
				0	12	24	36	48	60	72	84	96	108	120	
	HP	kW	3~	0	200	400	600	800	1000	1200	1400	1600	1800	2000	
FV 250-4 T	2,5	1,8	3,3	8,7	8,3	7,8	7,1	6,4	5,5	4,6	3,5	2,3			
FV 300-4 T	3	2,2	4,1	10,1	9,6	9	8,4	7,7	6,8	5,8	4,8	3,6	2,4		
FV 400-4 T	4	3	4,9	11,8	11,3	10,7	10	9,2	8,3	7,3	6,2	5	3,7	2,3	



# FV4

Q [imp g.p.m]  
Q [US g.p.m.]

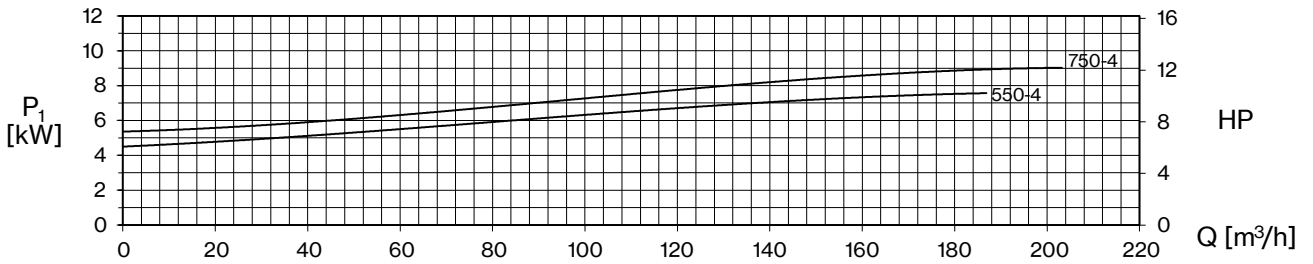
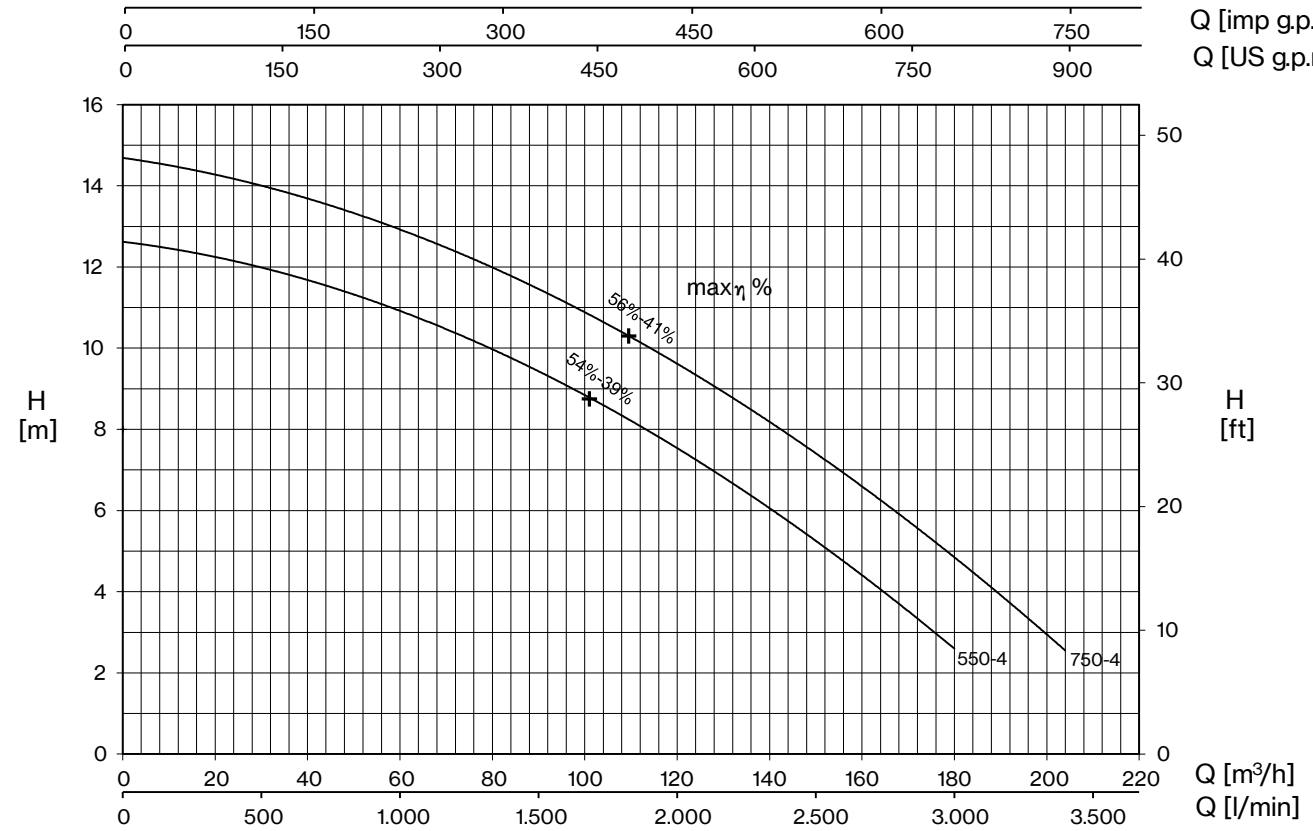

TYPE	AMPERE			
	3x230 V 50 Hz (*)	3x400 V 50 Hz	230/400 V 50 Hz λ / Δ (*)	400/690 V 50 Hz λ / Δ
FV 550-4 T	-	12,9	22,3	12,9
FV 750-4 T	-	15,4	26,6	15,4

+ max η %

max hydraulic efficiency and respective total efficiency

(\*) no standard execution

TYPE	P2		P1 (kW)	Q (m³/h - l/min)											
				0	24	48	72	96	120	144	168	180	192	204	
	HP	kW	3~	0	400	800	1200	1600	2000	2400	2800	3000	3200	3400	
FV 550-4 T	5,5	4	7,5	12,6	12,2	11,4	10,3	9,1	7,6	5,7	3,7	2,6			
FV 750-4 T	7,5	5,5	9	14,7	14,2	13,3	12,4	11,2	9,6	7,9	5,9	4,8	3,7	2,6	

# FV4

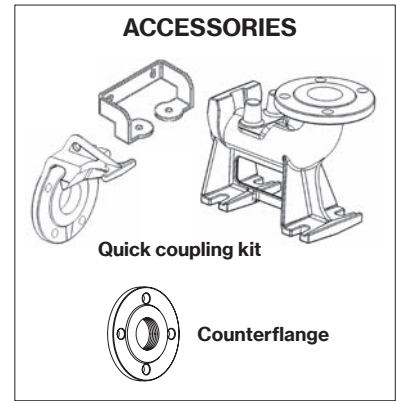
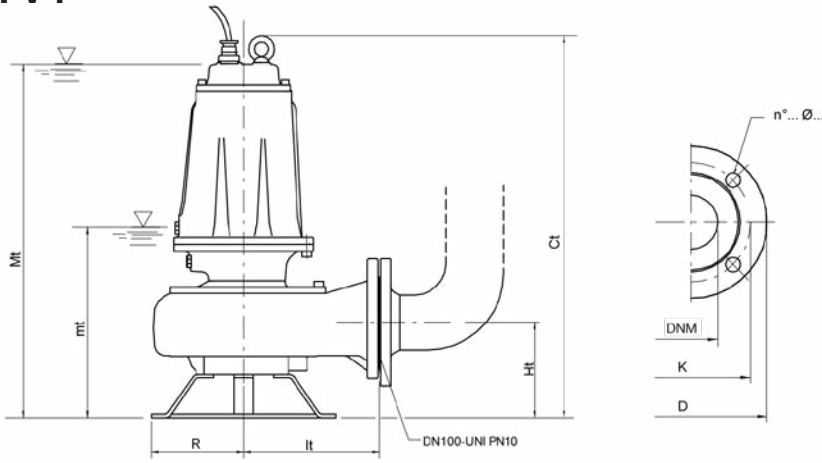

mt: minimum working level  
 Mt: minimum submersion level for continuous duty

TYPE	DIMENSIONS (mm)							Kg
	Ct	Ht	R	lt	mt	Mt	DNM	
FV 250-4 T	660	165	160	235	300	614	100	69,5
FV 300-4 T	660	165	160	235	300	614	100	71
FV 400-4 T	660	165	160	235	300	614	100	74,5
FV 550-4 T	715	195	180	276	385	695	100	101,5
FV 750-4 T	715	195	180	276	385	695	100	106

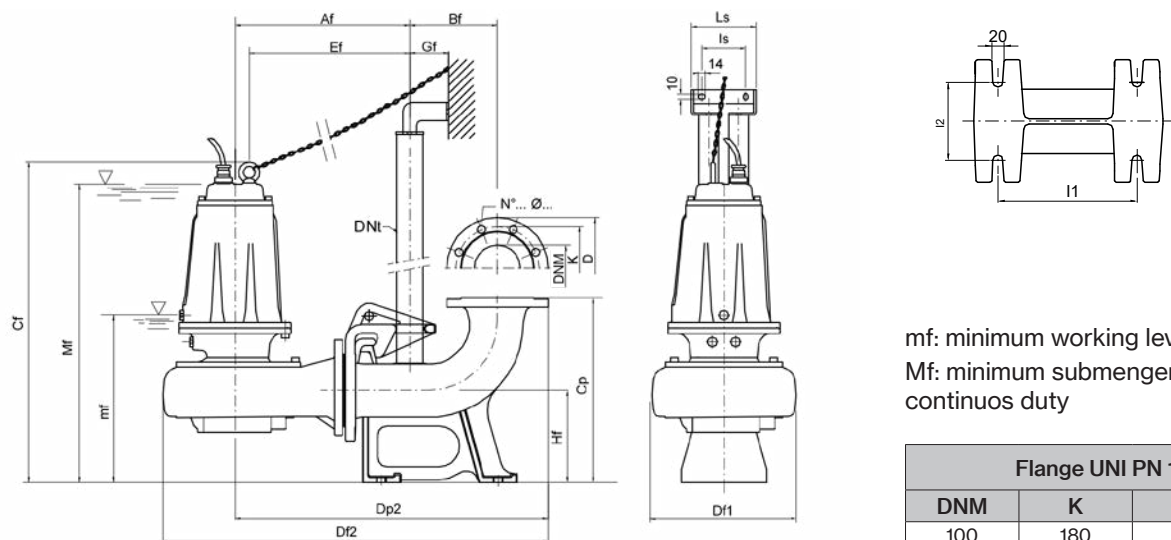

mf: minimum working level  
 Mf: minimum submersion level for continuous duty

Flange UNI PN 10 (mm)			
DNM	K	D	n°... Ø...
100	180	220	8... 18...

TYPE	DIMENSIONS (mm)																	
	Af	Bf	Cf	Cp	Df1	Df2	Dp2	DNt	Ef	Gf	Hf	l1	l2	ls	Ls	mf	Mf	DNM
FV 250-4 T/P	378	190	695	400	317	835	678	2"	347	85	200	250	140	130	180	335	650	100
FV 300-4 T/P	378	190	695	400	317	835	678	2"	347	85	200	250	140	130	180	335	650	100
FV 400-4 T/P	378	190	695	400	317	835	678	2"	347	85	200	250	140	130	180	335	650	100
FV 550-4 T/P	419	190	755	400	371	900	719	2"	384	85	200	250	140	130	180	390	700	100
FV 750-4 T/P	419	190	755	400	371	900	719	2"	384	85	200	250	140	130	180	390	700	100

TYPE	PROTECTION	1 PUMP CONTROL PANEL		2 PUMPS CONTROL PANEL	
	3 x 400 V	3 x 400 V	400 / 690 V	3 x 400 V	400 / 690 V
FV 250-4 T	PT 40-50/5.7-9.1	EQSMT 10		EQ2SMT 10	
FV 300-4 T	PT 40-50/5.7-9.1	EQSMT 10		EQ2SMT 10	
FV 400-4 T	PT 55-75/8.6-13.5	EQSMT 10		EQ2SMT 10	
FV 550-4 T	PT 55-75/8.6-13.5	EQSMT 10		EQ2SMT 10	
FV 750-4 T	PT 100/12.5-16.5	EQSMT 10	QST 10	EQ2SMT 10	Q2ST 10

