

More than you  
can see



## PRESSOSTATI PER INSTALLAZIONI IDRICHE PRESSURE SWITCHES FOR WATER SYSTEM APPLICATIONS



### Caratteristiche

- Pressostati per impiego in **sistemi autoclave**.
- L'interruttore regola automaticamente l'avvio e l'arresto dell'elettropompa secondo i valori di pressione impostati.
- Contatti elettrici normalmente chiusi in lega di ottone con riporto Ag-Ni.
- Membrana in NBR bianca con inserto in PA (nylon).
- Connessione idraulica ¼" F in acciaio zincato.
- Pressacavi antistrappo.
- Morsettiera con contatti elettrici non accessibili.

### Optional - esecuzioni speciali

- Numerose connessioni idrauliche disponibili.
- Flangia di connessione in acciaio inox ¼" femmina fisso e girevole conforme al D.M. 174/04 (uso con acqua potabile).
- Tarature personalizzate.
- Coperchio trasparente e scala graduata con indicazione della pressione di start.
- Coperchio con interruttore on/off.
- Contatti elettrici rinforzati per correnti fino a 20A.
- Grado di protezione IP 54.
- Versione dotata di cavi elettrici di collegamento per linea e motore.

### Features

- Pressure switches for **booster sets**.
- The switch automatically ensures the start and stop functions of the electric pump according to the set pressure values.
- Electric contacts: normally closed and made of brass alloy with Ag-Ni surfacing.
- NBR white membrane with insert in PA (nylon).
- ¼" F hydraulic connection made of galvanized steel.
- Tear resistant cable clamps.
- Terminal block with full insulated live parts.

### Optional - special arrangements

- Several available hydraulic connections.
- ¼" fix stainless steel connection flange and female revolving nut according to the Italian Ministerial Decree 174/04 (drinking water use).
- Customized settings.
- Transparent cover and graduated scale showing the cut-in pressure value.
- Cover with on/off button.
- Reinforced electric contacts up to 20A current.
- Protection degree IP 54.
- Version with electric cables for line and motor connection.



- ✓ AUTOCLAVE / BOOSTER SETS
- ✓ TRADIZIONALE / TRADITIONAL
- ✓ SICURO ED ECONOMICO / SAFE AND AFFORDABLE

Morsettiera con contatti protetti  
Fully insulated terminals



ON/OFF

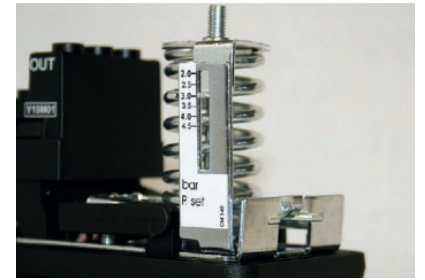

SG

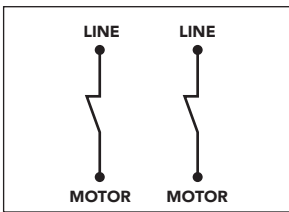

PM5 - PM6 - PM12

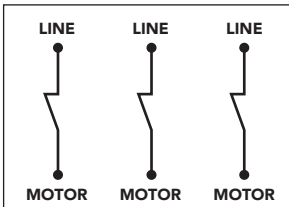

PT5 - PT6 - PT12

PM5 - PT5

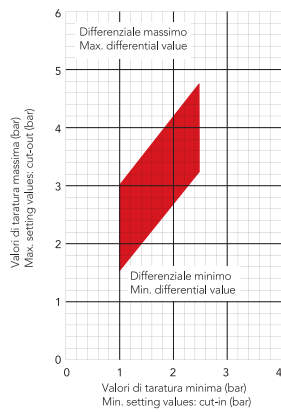

PM6 - PT6

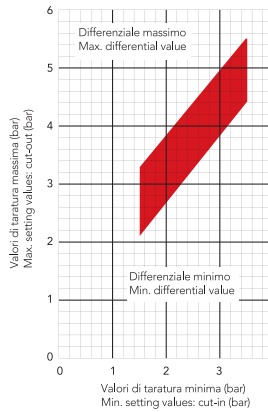

PM12 - PT12

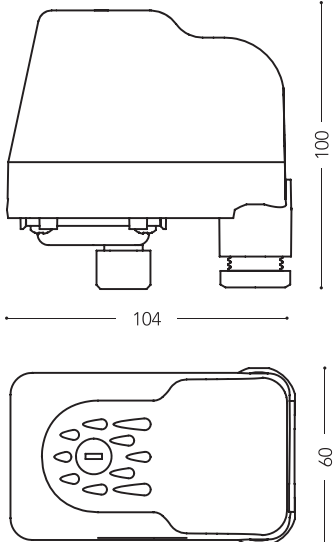
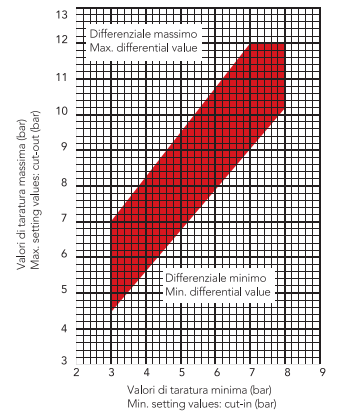

TECHNICAL DATA PM5 PM6 PM12 PT5 PT6 PT12

Campo di regolazione Pressure range	1÷4,8 bar	1,5÷5,5 bar	3÷12 bar	1÷4,8 bar	1,5÷5,5 bar	3÷12 bar
Taratura di fabbrica Factory setting	1,4-2,8 bar	1,8-3 bar	5-7 bar	1,4-2,8 bar	1,8-3 bar	5-7 bar
Differenziale minimo Min differential	0,6 bar	0,8 bar	1,5 bar	0,6 bar	0,8 bar	1,5 bar
Differenziale massimo Max differential	2,3 bar	2,2 bar	5 bar	2,3 bar	2,2 bar	5 bar
Corrente nominale Rated current	16(10)A					
Tensione nominale Rated voltage	250V			500V		
Grado di protezione Protection degree	IP 44					
Temperatura del fluido Fluid temperature	5°C+55°C					
Temperatura ambiente Ambient temperature	5°C+55°C					