

Stainless steel multistage vertical pumps. Suitable for clean non-loaded fluids, pressurizing system, irrigation, drinking and glycol water, water treatment, food industry, heating and air conditioning, washing system.



Construction features

Pump body	EN 1.4401 / AISI 316
Motor bracket	cast iron
Impellers, diffusers, shell, pump shaft	EN 1.4401 / AISI 316
Mechanical seal	silicon carbide-graphite-EPDM
Intermediate bush	tungsten carbide
Ambient temperature	max 40 °C
Liquid temperature	-15 ÷ +120 °C (Max 85° for domestic use)
Max operating pressure	max 26 bar
Pump body gasket	EPDM

Motor

2 pole induction motor	3~ 230/400V - 50Hz P ≤ 4kW, size B14 V1 3~ 400/690V - 50Hz P > 4kW, size B5 V1 IE3 efficiency class
Insulation class	F
Protection degree	IP55



P 18 H X - 100 / 1 T -2

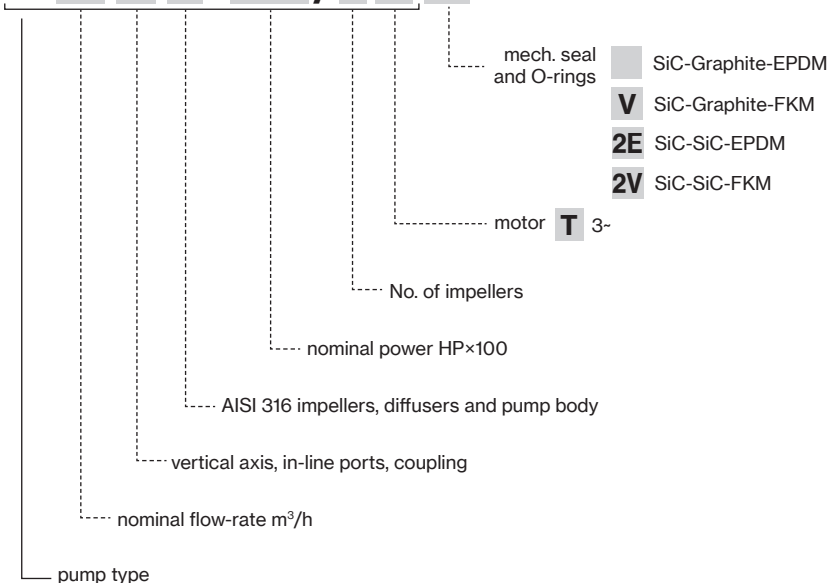

PLUS 18-22

TYPE	P2		Q (l/min - m ³ /h - US gpm)											
			0	133,3	150	166,7	183,3	200	216,7	233,3	266,7	300	350	400
3~	P2		0	8	9	10	11	12	13	14	16	18	21	24
	P2		0	35,2	39,6	44,0	48,4	52,8	57,2	61,6	70,3	79,1	92,3	105,5
	HP	kW	H (m)											
P 18HX-100/1T	1	0,75	13,0	11,7	11,6	11,4	11,1	10,8	10,4	10,1	9,1	7,9	5,6	
P 18HX-200/2T	2	1,5	27,1	24,3	23,9	23,5	22,9	22,3	21,7	21,1	19,3	17,2	13,1	8,0
P 18HX-300/3T	3	2,2	41,2	37,4	36,7	36,1	35,3	34,4	33,6	32,7	30,1	27,1	20,8	13,5
P 18HX-400/4T	4	3	55,1	50,2	49,3	48,5	47,5	46,3	45,2	44,0	40,6	36,6	28,2	18,5
P 18HX-550/5T	5,5	4	72,3	64,7	63,7	62,6	61,5	60,1	58,5	57,2	53,6	48,7	38,9	27,6
P 18HX-750/6T	7,5	5,5	88,0	80,1	78,9	77,7	76,4	74,9	73,3	71,7	68,0	62,4	51,3	37,5
P 18HX-750/7T	7,5	5,5	102,5	93,0	91,5	90,1	88,6	86,8	84,9	83,0	78,6	72,0	59,1	43,0
P 18HX-1000/8T	10	7,5	116,9	105,9	104,2	102,6	100,8	98,8	96,5	94,4	89,3	81,7	66,9	48,5
P 18HX-1000/9T	10	7,5	131,2	118,5	116,6	114,8	112,7	110,4	107,9	105,5	99,7	91,1	74,3	53,6
P 18HX-1500/10T	15	11	147,3	134,1	132,1	130,1	127,9	125,5	122,8	120,2	114,1	104,8	86,3	63,4
P 18HX-1500/11T	15	11	161,7	147,1	144,9	142,7	140,3	137,6	134,6	131,7	125,0	114,7	94,4	69,2
P 18HX-1500/12T	15	11	176,2	160,0	157,6	155,2	152,6	149,6	146,3	143,2	135,7	124,5	102,3	74,8
P 18HX-1500/13T	15	11	190,6	172,9	170,3	167,7	164,8	161,6	158,0	154,6	146,4	134,2	110,1	80,3
P 18HX-1500/14T	15	11	204,9	185,7	182,9	180,0	176,9	173,4	169,5	165,9	157,0	143,8	117,8	85,7
P 18HX-2000/15T	20	15	220,7	200,2	197,2	194,2	190,8	187,1	183,0	179,0	169,7	155,7	127,8	93,4
P 18HX-2000/16T	20	15	235,1	213,1	209,8	206,6	203,0	199,0	194,6	190,4	180,3	165,3	135,6	98,9
P 18HX-2000/17T	20	15	249,4	225,9	222,4	219,0	215,1	210,9	206,1	201,6	190,9	174,8	143,3	104,2

TYPE	P2		Q (l/min - m ³ /h - US gpm)											
			0	166,7	183,3	200	216,7	233,3	266,7	300	350	400	433,3	466,7
3~	P2		0	10	11	12	13	14	16	18	21	24	26	28
	P2		0	44,0	48,4	52,8	57,2	61,6	70,3	79,1	92,3	105,5	114,3	123,1
	HP	kW	H (m)											
P 22HX-200/1T	2	1,1	14,3	12,9	12,8	12,5	12,2	11,9	11,4	10,5	9,0	6,7	4,0	
P 22HX-300/2T	3	2,2	29,7	26,9	26,6	26,3	26,0	25,5	24,5	23,3	20,7	17,1	13,9	10,6
P 22HX-400/3T	4	3	45,0	40,9	40,4	39,9	39,2	38,5	37,2	35,5	31,6	25,8	21,5	16,6
P 22HX-550/4T	5,5	4	62,2	55,7	54,9	54,2	53,7	52,8	50,9	49,0	44,0	36,8	31,1	25,2
P 22HX-750/5T	7,5	5,5	78,6	70,8	69,9	69,0	68,5	67,4	65,1	62,8	56,9	47,9	41,0	33,5
P 22HX-1000/6T	10	7,5	94,2	86,2	85,1	84,1	83,2	82,2	79,7	77,3	70,0	59,4	51,3	42,0
P 22HX-1000/7T	10	7,5	109,5	99,8	98,5	97,4	96,3	95,1	92,2	89,2	80,6	68,2	58,7	47,9
P 22HX-1500/8T	15	11	126,5	116,1	114,7	113,5	112,3	111,0	107,9	104,8	95,4	81,4	70,7	58,3
P 22HX-1500/9T	15	11	142,0	130,2	128,6	127,2	125,9	124,4	120,8	117,3	106,7	90,8	78,7	64,8
P 22HX-1500/10T	15	11	157,5	144,2	142,4	140,8	139,3	137,7	133,6	129,6	117,7	100,1	86,6	71,1
P 22HX-2000/11T	20	15	174,0	159,4	157,4	155,7	154,1	152,3	147,9	143,5	130,5	111,2	96,4	79,3
P 22HX-2000/12T	20	15	189,5	173,4	171,2	169,3	167,6	165,5	160,7	155,8	141,6	120,4	104,2	85,6
P 22HX-2000/13T	20	15	204,9	187,3	184,9	182,8	180,9	178,7	173,4	168,1	152,5	129,5	111,9	91,7
P 22HX-2000/14T	20	15	220,3	201,1	198,5	196,2	194,1	191,7	186,0	180,2	163,2	138,4	119,4	97,7
P 22HX-2500/15T	25	18,5	237,4	218,1	215,4	213,1	211,0	208,6	202,6	196,8	179,4	153,1	133,0	109,7
P 22HX-2500/16T	25	18,5	252,9	232,2	229,4	226,9	224,6	222,0	215,6	209,4	190,7	162,7	141,1	116,3
P 22HX-2500/17T	25	18,5	268,5	246,3	243,3	240,6	238,2	235,4	228,6	221,9	202,0	172,1	149,2	122,8

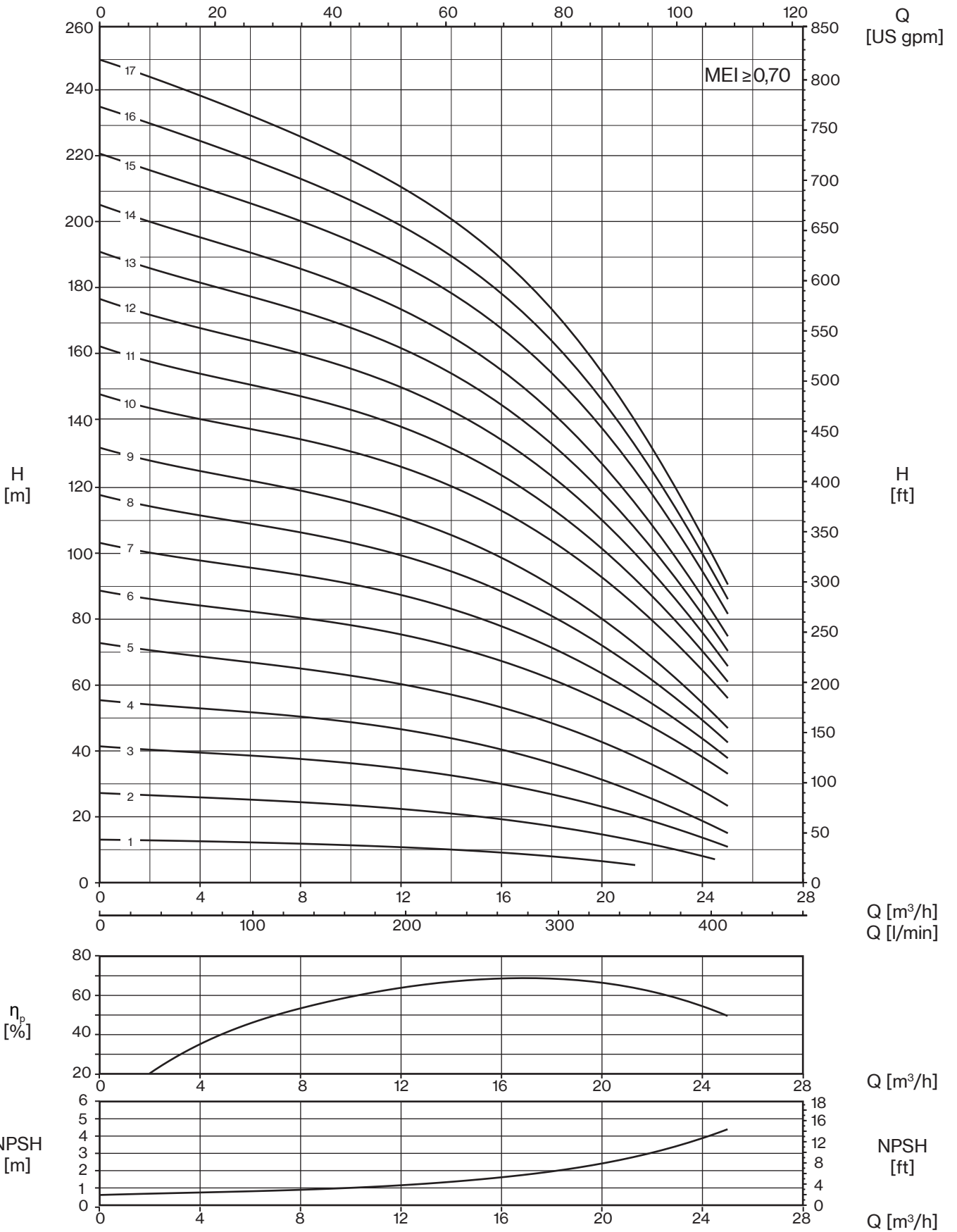

22 HX

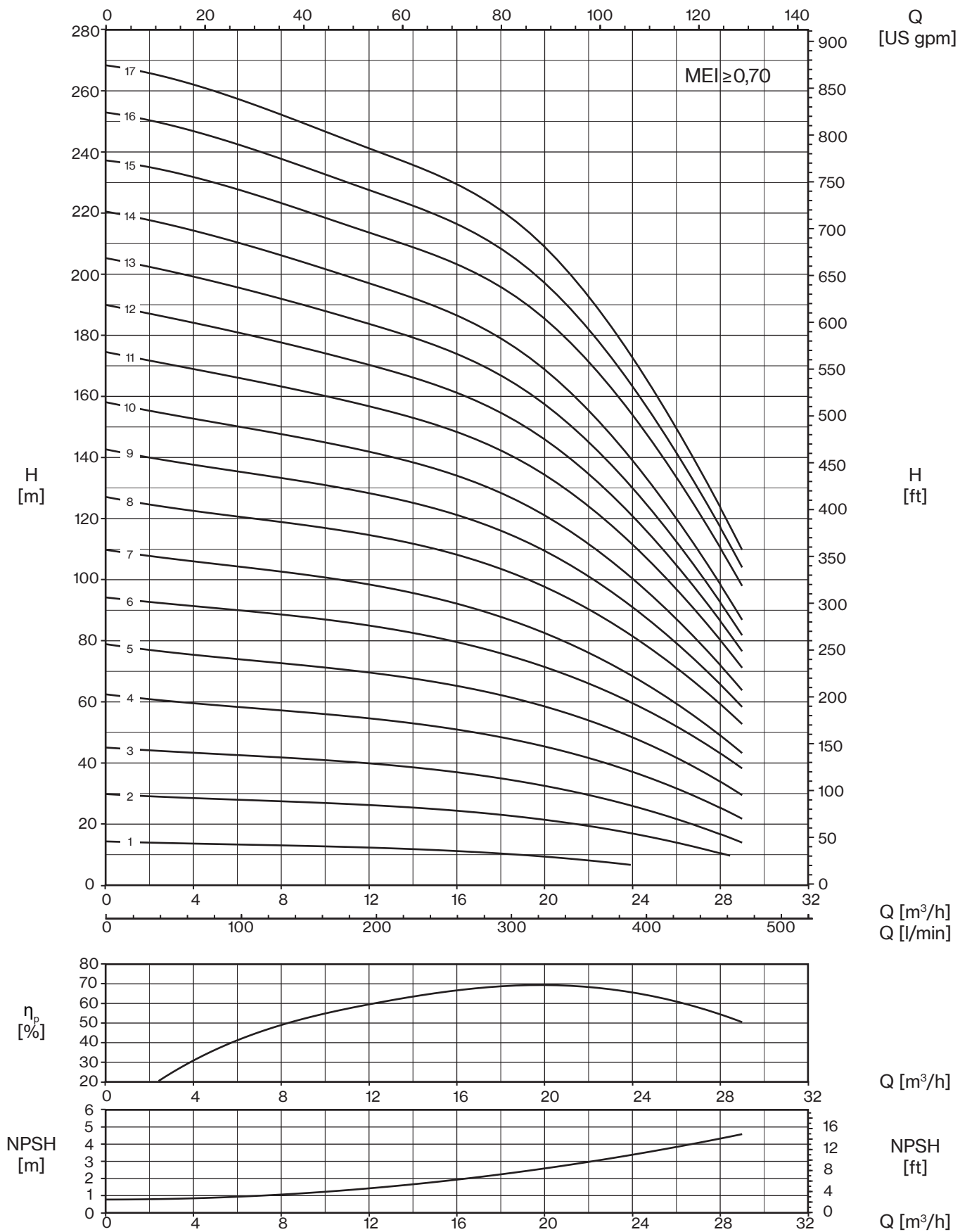

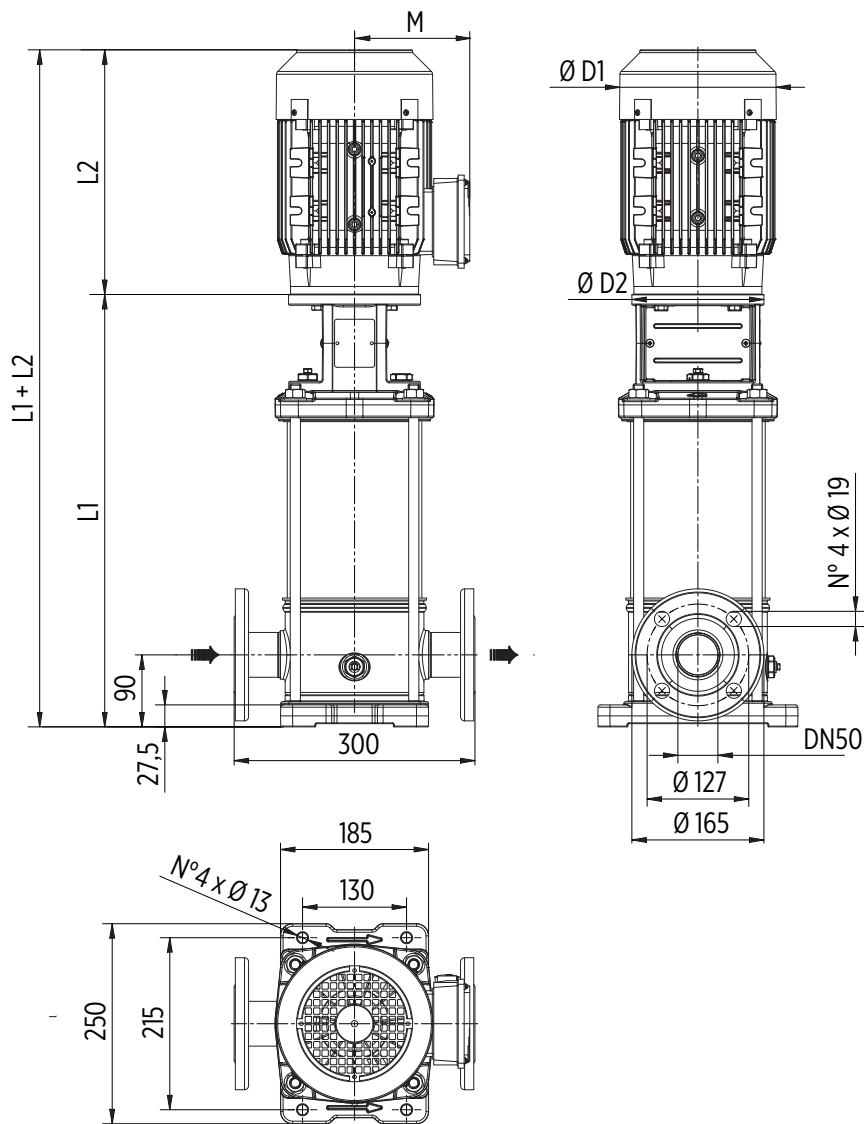

Round flanges on body type PN25/40: the pump is supplied without counterflanges (optional accessories, including bolts and joints)

TYPE	MOTOR		DIMENSIONS (mm)						Kg		
	kW	Dim	L1	L2	M	D1	D2	L1+L2	Pump	Motor	Electric Pump
P 18HX-100/1T	0,75	80	396	243	130	157	170	639	19	17	36
P 18HX-200/2T	1,5	90	396	280	145	177	170	676	20	23	43
P 18HX-300/3T	2,2	90	444	308	145	177	170	752	21,5	26	47,5
P 18HX-400/4T	3	100	492	333	157	205	170	825	22,5	35	57,5
P 18HX-550/5T	4	112	540	350	177	220	170	890	24	43	67
P 18HX-750/6T	5,5	132	800	400	197	256	300	1200	45,5	66	111,5
P 18HX-750/7T	5,5	132	848	400	197	256	300	1248	46,5	66	112,5
P 18HX-1000/8T	7,5	132	896	400	197	256	300	1296	48	73	121
P 18HX-1000/9T	7,5	132	944	400	197	256	300	1344	49,5	73	122,5
P 18HX-1500/10T	11	160	1012	503	255	315	350	1515	54	120	174
P 18HX-1500/11T	11	160	1060	503	255	315	350	1563	55,5	120	175,5
P 18HX-1500/12T	11	160	1108	503	255	315	350	1611	57	120	177
P 18HX-1500/13T	11	160	1156	503	255	315	350	1659	58,5	120	178,5
P 18HX-1500/14T	11	160	1204	503	255	315	350	1707	60	120	180
P 18HX-2000/15T	15	160	1252	503	255	315	350	1755	61	132	193
P 18HX-2000/16T	15	160	1300	503	255	315	350	1803	62,5	132	194,5
P 18HX-2000/17T	15	160	1348	503	255	315	350	1851	64	132	196

22 HX

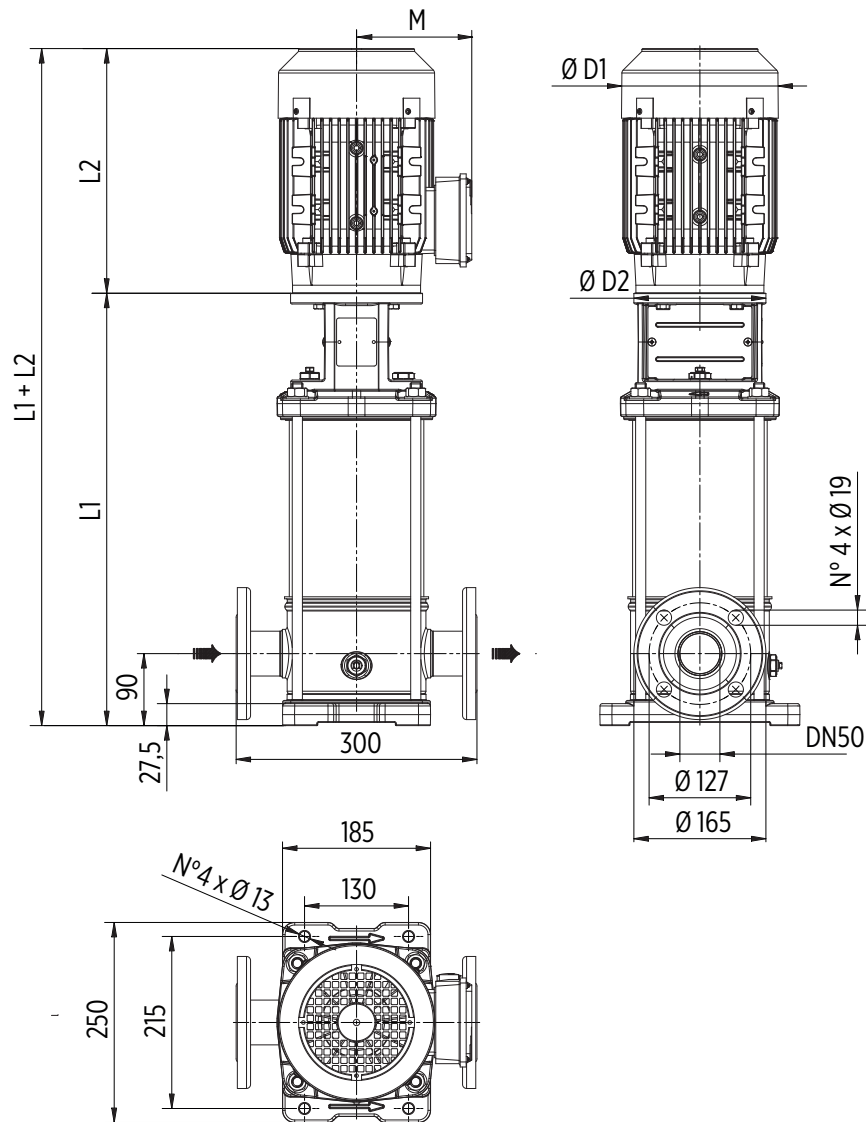

Round flanges on body type PN25/40: the pump is supplied without counterflanges (optional accessories, including bolts and joints)

TYPE	MOTOR		DIMENSIONS (mm)						Kg		
	kW	Dim	L1	L2	M	D1	D2	L1+L2	Pump	Motor	Electric Pump
P 22HX-200/1T	1,1	80	396	243	130	157	170	639	19	18	37
P 22HX-300/2T	2,2	90	396	308	145	177	170	704	20	26	46
P 22HX-400/3T	3	100	444	333	157	205	170	777	21,5	35	56,5
P 22HX-550/4T	4	112	492	350	177	220	170	842	22,5	43	65,5
P 22HX-750/5T	5,5	132	752	400	197	256	300	1152	44	66	110
P 22HX-1000/6T	7,5	132	800	400	197	256	300	1200	45,5	73	118,5
P 22HX-1000/7T	7,5	132	848	400	197	256	300	1248	46,5	73	119,5
P 22HX-1500/8T	11	160	916	503	255	315	350	1419	51,5	120	171,5
P 22HX-1500/9T	11	160	964	503	255	315	350	1467	53	120	173
P 22HX-1500/10T	11	160	1012	503	255	315	350	1515	54,5	120	174,5
P 22HX-2000/11T	15	160	1060	503	255	315	350	1563	55,5	132	187,5
P 22HX-2000/12T	15	160	1108	503	255	315	350	1611	57	132	189
P 22HX-2000/13T	15	160	1156	503	255	315	350	1659	58,5	132	190,5
P 22HX-2000/14T	15	160	1204	503	255	315	350	1707	60	132	192
P 22HX-2500/15T	18,5	160	1252	598	252	315	350	1850	61,5	150	211,5
P 22HX-2500/16T	18,5	160	1300	598	252	315	350	1898	62,5	150	212,5
P 22HX-2500/17T	18,5	160	1348	598	252	315	350	1946	64	150	214

PLUS HS-HX Serie-Mechanical seal and bearings

CARTRIDGE MECHANICAL SEAL	PUMP MODEL	SHAFT		STANDARD MATERIAL	OPTIONAL		
					V	2	2V
	P18-100/1T, P18-200/2T, P18-300/3T, P18-400/4T, P18-550/5T, P18-750/6T, P18-750/7T, P18-1000/8T, P18-1000/9T, P18-1500/10T, P18-1500/11T, P18-1500/12T, P18-1500/13T, P18-1500/14T, P18-2000/15T, P18-2000/16T, P18-2000/17T, P22-150/1T, P22-300/2T, P22-400/3T, P22-550/4T, P22-750/5T, P22-1000/6T, P22-1000/7T, P22-1500/8T, P22-1500/9T, P22-1500/10T, P22-2000/11T, P22-2000/12T, P22-2000/13T	16mm	Rotating face Stationary face Elastomer	SiC Graphite EPDM	SiC Graphite FKM	SiC SiC EPDM	SiC SiC FKM
	P35-300/1T, P35-550/2-2RT, P35-550/2-1RT, P35-750/2T, P35-750/3-2RT, P35-1000/3-1RT, P35-1000/3T, P35-1000/4-2RT, P35-1500/4-1RT, P35-1500/4T, P35-1500/5-2RT, P35-1500/5-1RT, P35-2000/5T, P35-2000/6-2RT, P35-2000/6-1RT, P35-2000/6T, P35-2000/7-2RT, P35-2000/7-1RT, P35-2500/7T, P35-2500/8-2RT, P35-2500/8-1RT, P35-2500/8T, P35-3000/9-2RT, P35-3000/9-1RT, P35-3000/9T, P35-3000/10-2RT, P35-3000/10-1RT, P35-4000/10T, P35-4000/11-2RT, P35-4000/11-1RT, P35-4000/11T, P35-4000/12-2RT, P35-4000/12-1RT, P35-4000/12T, P35-4000/13-2RT, P35-4000/13-1RT, P35-4000/13T, P50-400/1-1RT, P50-550/1T, P50-750/2-2RT, P50-1000/2T, P50-1500/3-2RT, P50-1500/3T, P50-2000/4-2RT, P50-2000/4T, P50-2500/5-2RT, P50-2500/5T, P50-3000/6-2RT, P50-3000/6T, P50-4000/7-2RT, P50-4000/7T, P50-4000/8-2RT, P50-4000/8T, P50-5000/9-2RT, P50-5000/9T, P50-5000/10-2RT, P50-5000/10T, P50-6000/11-2RT, P50-6000/11T, P50-6000/12-2RT, P50-6000/12T, P50-6000/13-2RT, P75-550/1-1RT, P75-750/1T, P75-1000/2-2RT, P75-1500/2-1RT, P75-1500/2T, P75-2000/3-2RT, P75-2000/3-1RT, P75-2500/3T, P75-2500/4-2RT, P75-3000/4-1RT, P75-3000/4T, P75-4000/5-2RT, P75-4000/5-1RT, P75-4000/5T, P75-4000/6-2RT, P75-5000/6-1RT, P75-5000/6T, P75-5000/7-2RT, P75-5000/7-1RT, P75-6000/7T, P75-6000/8-2RT, P75-6000/8-1RT, P75-6000/8T, P90-750/1-1RT, P90-1000/1T, P90-1500/2-2RT, P90-2000/2T, P90-2500/3-2RT, P90-3000/3T, P90-4000/4-2RT, P90-4000/4T, P90-5000/5-2RT, P90-5000/5T, P90-6000/6-2RT, P90-6000/6T	22mm / Balanced seal	Rotating face Stationary face Elastomer	SiC Graphite EPDM	SiC Graphite FKM	SiC SiC EPDM	SiC SiC FKM

BEARINGS	PUMP MODEL	PUMP THRUST BEARING		MOTOR BEARING	
	P18-100/1T, P22-150/1T	-	-	6204-ZZ C3	6204-ZZ C3
	P18-200/2T, P18-300/3T, P22-300/2T, P35-300/1T	-	-	6205-ZZ C3	6205-ZZ C3
	P18-400/4T, P18-550/5T, P22-400/3T, P22-550/4T, P35-550/2-2RT, P35-550/2-1RT, P50-400/1-1RT, P50-550/1T, P75-550/1-1RT	-	-	6206-ZZ C3	6206-ZZ C3
	P18-750/6T, P18-750/7T, P18-1000/8T, P18-1000/9T, P22-750/5T, P22-1000/6T, P22-1000/7T, P35-750/2T, P35-750/3-2RT, P35-1000/3-1RT, P35-1000/3T, P35-1000/4-2RT, P50-750/2-2RT, P50-1000/2T, P75-750/1T, P75-1000/2-2RT, P90-750/1-1RT, P90-1000/1T			6208-ZZ C3	6208-ZZ C3
	P18-1500/10T, P18-1500/11T, P18-1500/12T, P18-1500/13T, P18-1500/14T, P18-2000/15T, P18-2000/16T, P18-2000/17T, P22-1500/8T, P22-1500/9T, P22-1500/10T, P22-2000/11T, P22-2000/12T, P22-2000/13T, P22-2000/14T, P22-2500/15T, P22-2500/16T, P22-2500/17T, P35-1500/4-1RT, P35-1500/4T, P35-1500/5-2RT, P35-1500/5-1RT, P50-1500/3-2RT, P50-1500/3T, P75-1500/2-1RT, P75-1500/2T, P90-1500/2-2RT	6212 ZZ	-		
	P35-2000/5T, P35-2000/6-2RT, P35-2000/6-1RT, P35-2000/6T, P35-2000/7-2RT, P35-2000/7-1RT, P35-2500/7T, P35-2500/8-2RT, P35-2500/8-1RT, P35-2500/8T, P50-2000/4-2RT, P50-2000/4T, P50-2500/5-2RT, P50-2500/5T, P75-2000/3-2RT, P75-2000/3-1RT, P75-2500/3T, P75-2500/4-2RT, P90-2000/2T, P90-2500/3-2RT	6212 ZZ	7212 BEP		
	P35-3000/9-2RT, P35-3000/9-1RT, P35-3000/9T, P35-3000/10-2RT, P35-3000/10-1RT, P50-3000/6-2RT, P50-3000/6T, P75-3000/4-1RT, P75-3000/4T, P90-3000/3T			6311-ZZ C3	6311-ZZ C3
	P35-4000/10T, P35-4000/11-2RT, P35-4000/11-1RT, P35-4000/11T, P35-4000/12-2RT, P35-4000/12-1RT, P35-4000/12T, P35-4000/13-2RT, P35-4000/13-1RT, P35-4000/13T, P50-4000/7-2RT, P50-4000/7T, P50-4000/8-2RT, P50-4000/8T, P50-5000/9-2RT, P50-5000/9T, P50-5000/10-2RT, P50-5000/10T, P75-4000/5-2RT, P75-4000/5-1RT, P75-4000/5T, P75-4000/6-2RT, P75-5000/6-1RT, P75-5000/6T, P75-5000/7-2RT, P75-5000/7-1RT, P90-4000/4-2RT, P90-4000/4T, P90-5000/5-2RT, P90-5000/5T	6214 ZZ	7214 BEP	6312-ZZ C3	6312-ZZ C3
P50-6000/11-2RT, P50-6000/11T, P50-6000/12-2RT, P50-6000/12T, P50-6000/13-2RT, P75-6000/7T, P75-6000/8-2RT, P75-6000/8-1RT, P75-6000/8T, P90-6000/6-2RT, P90-6000/6T			6313-ZZ C3	6313-ZZ C3	

PLUS HS/HX

Multistage Vertical

Stainless steel multistage vertical pumps. Suitable for clean non-loaded fluids, pressurizing system, irrigation, drinking and glycol water, water treatment, food industry, heating and air conditioning, washing system.

Construction features

Pump body	HS: cast iron GJL-250 HX: EN 1.4401 / AISI 316
Motor bracket	cast iron
Seal plate housing	HS: EN 1.4301 / AISI 304 HX: EN 1.4401 / AISI 316
Impellers, diffusers, shell	HS: EN 1.4301 / AISI 304 HX: EN 1.4401 / AISI 316
Pump shaft	HS: EN 1.4057 / AISI 431 HX: EN 1.4460 / AISI 329
Mechanical seal	silicon carbide-graphite-EPDM
Intermediate bush	tungsten carbide
Ambient temperature	max 40 °C
Liquid temperature	-15 ÷ +120 °C (Max 85° for domestic use)
Max operating pressure	32 bar (P 35-50) 25 bar (P 75-90)
Pump body gasket	EPDM

Motor

2 pole induction motor	3~ 230/400V - 50Hz P ≤ 4kW, size B14 V1 3~ 400/690V - 50Hz P > 4kW, size B5 V1 IE3 efficiency class
Insulation class	F
Protection degree	IP55



PLUS HS

PLUS HX

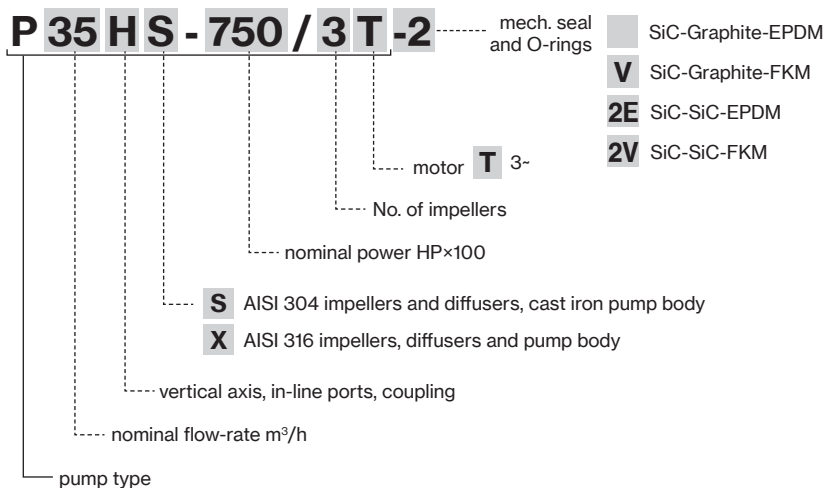

PLUS 35-50

TYPE	P2		Q (l/min - m³/h - US gpm)																	
			0	417	500	566,7	666,7	700	800	900	1000	1066,7								
			0	25	30	34	40	42	48	54	60	64								
3~	HP	kW	H (m)																	
			0	109,9	131,9	149,5	175,9	184,7	211,0	237,4	263,8	281,4								
P 35...-300/1T	3	2,2	24,8	18,6	17,2	15,8	12,7	11,6												
P 35...-550/2-2RT	5,5	4	36,2	29,3	26,3	23,1	17,8	15,7												
P 35...-550/2-1RT	5,5	4	42,8	34,3	31,6	28,8	23,4	21,3												
P 35...-750/2T	7,5	5,5	48,5	39,6	36,9	34,4	29,1	27,2												
P 35...-750/3-2RT	7,5	5,5	60,3	49,0	44,9	40,6	32,7	29,6												
P 35...-1000/3-1RT	10	7,5	67,5	54,1	50,1	46,1	38,0	35,0												
P 35...-1000/3T	10	7,5	72,2	58,2	54,2	50,3	42,4	39,5												
P 35...-1000/4-2RT	10	7,5	85,1	68,6	63,9	58,4	48,8	44,7												
P 35...-1500/4-1RT	15	11	92,8	75,3	70,2	65,2	54,8	50,8												
P 35...-1500/4T	15	11	99,4	81,0	76,3	71,8	62,2	58,5												
P 35...-1500/5-2RT	15	11	109,2	89,5	82,9	76,2	63,5	58,5												
P 35...-1500/5-1RT	15	11	115,1	93,6	87,0	80,6	67,5	62,4												
P 35...-2000/5T	20	15	121,1	99,3	93,1	87,4	74,9	70,0												
P 35...-2000/6-2RT	20	15	133,8	109,6	101,7	93,9	78,7	72,7												
P 35...-2000/6-1RT	20	15	139,7	113,7	105,8	98,3	82,7	76,6												
P 35...-2000/6T	20	15	145,6	119,3	111,9	105,0	90,1	84,2												
P 35...-2000/7-2RT	20	15	157,5	128,3	119,1	110,1	92,3	85,3												
P 35...-2000/7-1RT	20	15	163,3	132,3	123,2	114,4	96,2	89,1												
P 35...-2500/7T	25	18,5	169,2	137,9	129,1	121,0	103,5	96,6												
P 35...-2500/8-2RT	25	18,5	185,5	152,0	142,0	132,5	112,8	105,1												
P 35...-2500/8-1RT	25	18,5	191,9	156,4	146,6	137,4	117,4	109,6												
P 35...-2500/8T	25	18,5	198,4	162,5	153,0	144,6	125,4	117,8												
P 35...-3000/9-2RT	30	22	209,8	171,4	160,2	149,5	127,4	118,7												
P 35...-3000/9-1RT	30	22	216,2	175,8	164,7	154,4	131,9	123,1												
P 35...-3000/9T	30	22	222,7	181,8	171,1	161,5	139,8	131,3												
P 35...-3000/10-2RT	30	22	234,0	190,6	178,1	166,3	141,7	132,1												
P 35...-3000/10-1RT	30	22	240,3	194,9	182,6	171,1	146,1	136,4												
P 35...-4000/10T	40	30	246,8	200,9	188,9	178,2	154,0	144,5												
P 35...-4000/11-2RT	40	30	262,9	218,3	205,1	192,7	166,3	155,8												
P 35...-4000/11-1RT	40	30	269,5	222,9	209,9	197,8	171,2	160,5												
P 35...-4000/11T	40	30	276,2	229,2	216,5	205,3	179,4	169,1												
P 35...-4000/12-2RT	40	30	288,1	240,0	226,0	213,0	184,4	173,3												
P 35...-4000/12-1RT	40	30	294,7	244,8	230,9	218,4	189,7	178,6												
P 35...-4000/12T	40	30	301,4	251,1	237,8	226,0	197,6	188,0												
P 35...-4000/13-2RT	40	30	313,0	260,4	245,3	231,3	200,3	188,3												
P 35...-4000/13-1RT	40	30	319,6	265,2	250,2	236,6	205,6	193,6												
P 35...-4000/13T	40	30	326,3	271,5	257,0	244,2	213,5	202,9												
P 50...-400/1-1RT	4	3	19,6			16,0	14,6	14,0	12,1	9,7	7,0	4,9								
P 50...-550/1T	5,5	4	25,1			20,4	19,0	18,5	16,8	14,8	12,5	10,4								
P 50...-750/2-2RT	7,5	5,5	38,4			33,9	31,5	30,5	27,4	23,7	19,3	16,0								
P 50...-1000/2T	10	7,5	49,0			42,0	39,8	38,8	35,5	31,8	27,5	24,1								
P 50...-1500/3-2RT	15	11	63,0			55,9	52,7	51,4	46,8	41,5	35,1	30,3								
P 50...-1500/3T	15	11	74,2			65,0	62,1	60,9	56,5	51,3	45,5	41,0								
P 50...-2000/4-2RT	20	15	87,5			77,4	73,3	71,6	65,5	58,4	50,1	43,8								
P 50...-2000/4T	20	15	97,5			86,4	82,8	81,3	75,4	68,5	60,8	54,7								
P 50...-2500/5-2RT	25	18,5	112,1			99,9	95,0	92,9	85,5	76,7	66,6	58,8								
P 50...-2500/5T	25	18,5	122,3			109,1	104,7	102,9	95,6	87,1	77,5	70,0								
P 50...-3000/6-2RT	30	22	136,0			120,7	114,9	112,4	103,4	92,9	80,8	71,5								
P 50...-3000/6T	30	22	146,0			129,8	124,5	122,2	113,3	103,0	91,6	82,5								
P 50...-4000/7-2RT	40	30	162,6			146,4	140,1	137,3	127,2	115,2	101,3	90,8								
P 50...-4000/7T	40	30	173,0			155,9	150,1	147,7	137,7	126,0	112,7	102,5								
P 50...-4000/8-2RT	40	30	187,2			168,3	161,1	158,0	146,4	132,7	116,8	104,8								
P 50...-4000/8T	40	30	197,5			177,7	171,1	168,2	156,8	143,4	128,2	116,5								
P 50...-5000/9-2RT	50	37	211,7			190,2	182,2	178,7	165,7	150,3	132,6	119,1								
P 50...-5000/9T	50	37	222,0			199,7	192,2	188,9	176,1	161,0	143,9	130,7								
P 50...-5000/10-2RT	50	37	236,1			211,9	203,0	199,1	184,6	167,5	147,9	132,9								
P 50...-5000/10T	50	37	246,4			221,3	212,9	209,3	195,0	178,1	159,1	144,4								
P 50...-6000/11-2RT	60	45	261,5			235,3	225,7	221,5	205,7	187,0	165,5	149,1								
P 50...-6000/11T	60	45	271,8			244,8	235,7	231,8	216,2	197,7	176,9	160,9								
P 50...-6000/12-2RT	60	45	286,0			257,2	246,7	242,1	224,8	204,5	181,0	163,2								
P 50...-6000/12T	60	45	296,3			266,6	256,7	252,4	235,3	215,2	192,4	174,9								

TYPE	P2		Q (l/min - m ³ /h - US gpm)								
			0	500	666,7	750	833,3	1000	1166,7	1333,3	1466,7
			0	30	40	45	50	60	70	80	88
			0	131,9	175,9	197,9	219,8	263,8	307,8	351,7	386,9
3~	HP	kW	H (m)								
			P 75...-550/1-1RT	5,5	4	21,3	18,2	17,0	16,3	15,5	13,3
P 75...-750/1T	7,5	5,5	30,2	24,8	23,0	22,3	21,7	20,3	18,3	15,4	12,2
P 75...-1000/2-2RT	10	7,5	38,9	37,2	35,8	34,8	33,8	30,5	25,8	20,3	14,6
P 75...-1500/2-1RT	15	11	47,8	44,3	42,6	41,6	40,6	38,0	34,2	29,3	24,0
P 75...-1500/2T	15	11	59,3	51,2	48,0	46,8	45,5	43,2	39,9	35,3	30,8
P 75...-2000/3-2RT	20	15	67,3	63,0	60,6	59,1	57,6	53,4	47,2	39,5	31,4
P 75...-2000/3-1RT	20	15	75,5	69,2	66,3	64,8	63,2	59,5	54,1	46,9	38,7
P 75...-2500/3T	25	18,5	89,6	77,6	72,8	70,9	69,0	65,7	60,7	53,9	47,2
P 75...-2500/4-2RT	25	18,5	95,5	88,6	85,1	83,2	81,1	76,0	68,3	58,5	47,9
P 75...-3000/4-1RT	30	22	103,7	94,7	90,9	88,8	86,7	82,1	75,2	65,9	55,3
P 75...-3000/4T	30	22	111,8	100,8	96,7	94,5	92,4	88,4	82,3	73,3	62,9
P 75...-4000/5-2RT	40	30	125,3	116,2	111,8	109,5	107,0	101,1	92,1	80,4	68,0
P 75...-4000/5-1RT	40	30	133,9	122,7	117,9	115,5	113,0	107,6	99,5	88,4	76,2
P 75...-4000/5T	40	30	142,4	129,2	124,0	121,5	119,0	114,1	106,9	96,3	84,6
P 75...-4000/6-2RT	40	30	153,5	141,6	136,2	133,3	130,3	123,4	112,9	99,0	84,1
P 75...-5000/6-1RT	50	37	162,1	148,2	142,4	139,4	136,4	130,0	120,4	107,1	92,5
P 75...-5000/6T	50	37	170,6	154,7	148,5	145,4	142,3	136,5	127,8	115,0	100,9
P 75...-5000/7-2RT	50	37	181,7	167,0	160,6	157,2	153,6	145,7	133,7	117,7	100,3
P 75...-5000/7-1RT	50	37	190,1	173,5	166,6	163,1	159,5	152,1	141,0	125,5	108,3
P 75...-6000/7T	60	45	199,5	181,1	173,8	170,3	166,7	160,0	149,9	135,1	118,9
P 75...-6000/8-2RT	60	45	210,6	193,5	186,0	182,2	178,1	169,3	156,0	137,9	118,4
P 75...-6000/8-1RT	60	45	219,2	200,0	192,1	188,2	184,1	175,8	163,4	145,9	126,6
P 75...-6000/8T	60	45	227,7	206,5	198,2	194,1	190,1	182,3	170,7	153,8	135,1

TYPE	P2		Q (l/min - m ³ /h - US gpm)									
			0	750	833,3	1000	1166,7	1333,3	1466,7	1666,7	1833,3	1916,7
			0	45	50	60	70	80	88	100	110	115
			0	197,9	219,8	263,8	307,8	351,7	386,9	439,7	483,6	505,6
3~	HP	kW	H (m)									
			P 90...-750/1-1RT	7,5	5,5	26,4	20,5	19,9	18,7	17,3	15,5	13,2
P 90...-1000/1T	10	7,5	35,6	27,0	25,6	23,2	21,9	20,4	18,8	15,7	12,4	10,5
P 90...-1500/2-2RT	15	11	49,6	42,4	41,3	39,0	36,6	33,2	29,4	22,7	15,7	11,7
P 90...-2000/2T	20	15	69,2	56,6	54,5	50,5	47,3	44,3	41,6	36,3	30,5	27,3
P 90...-2500/3-2RT	25	18,5	80,4	70,8	69,1	65,6	62,2	57,7	53,0	44,3	34,9	30,4
P 90...-3000/3T	30	22	92,4	82,6	80,6	76,7	73,2	69,4	65,5	57,8	49,7	45,2
P 90...-4000/4-2RT	40	30	113,1	100,6	98,2	93,5	89,0	83,5	77,5	66,5	54,6	48,5
P 90...-4000/4T	40	30	125,6	113,0	110,4	105,2	100,6	95,7	90,7	80,8	70,2	64,4
P 90...-5000/5-2RT	50	37	144,1	128,4	125,4	119,3	113,7	106,9	99,7	86,1	71,6	64,1
P 90...-5000/5T	50	37	156,6	140,7	137,4	130,9	125,2	119,1	112,8	100,3	87,1	79,8
P 90...-6000/6-2RT	60	45	175,9	157,0	153,4	146,1	139,3	131,4	122,9	107,0	89,8	80,8
P 90...-6000/6T	60	45	188,4	169,5	165,6	157,8	150,9	143,6	136,2	121,3	105,5	96,7

35 HS/HX

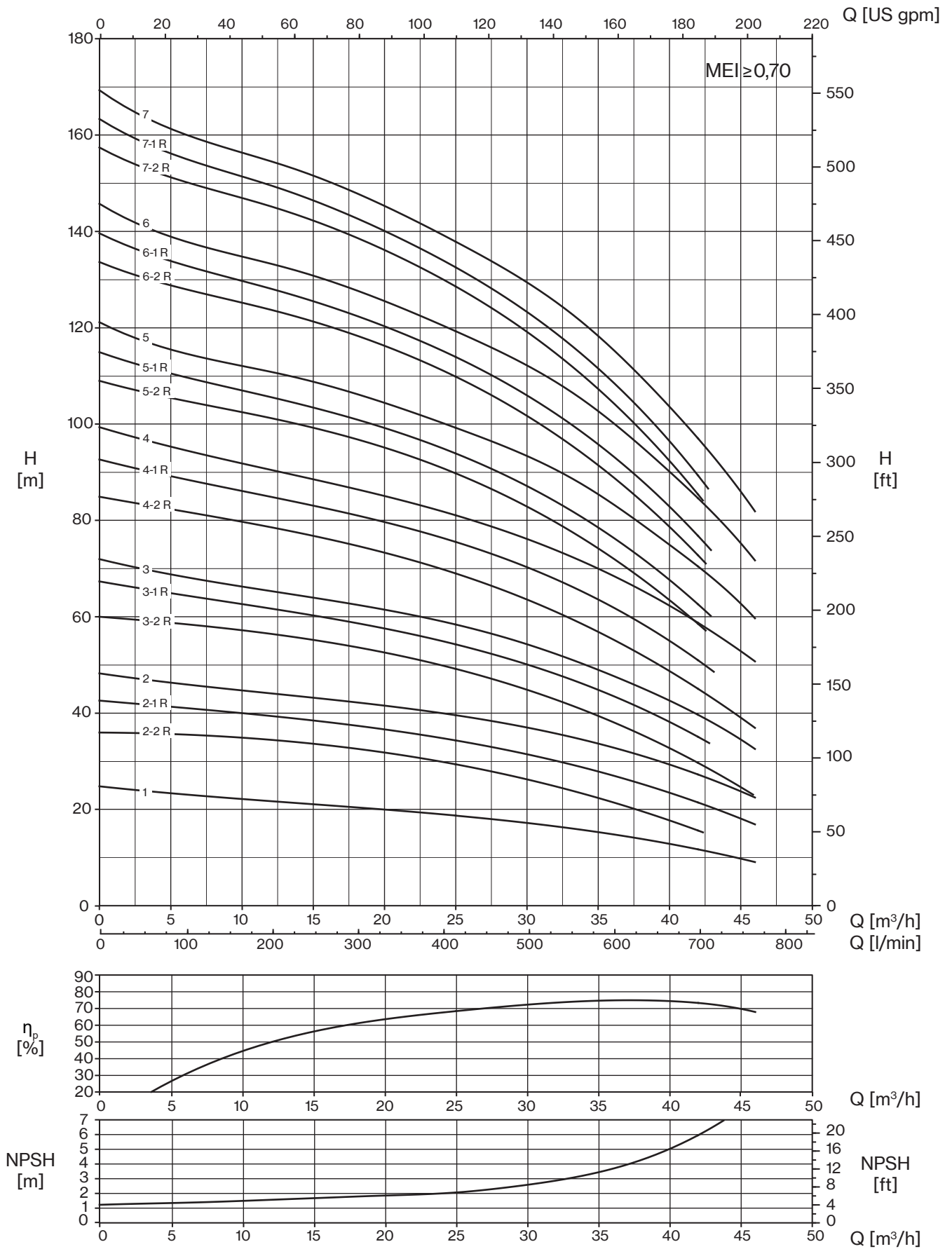

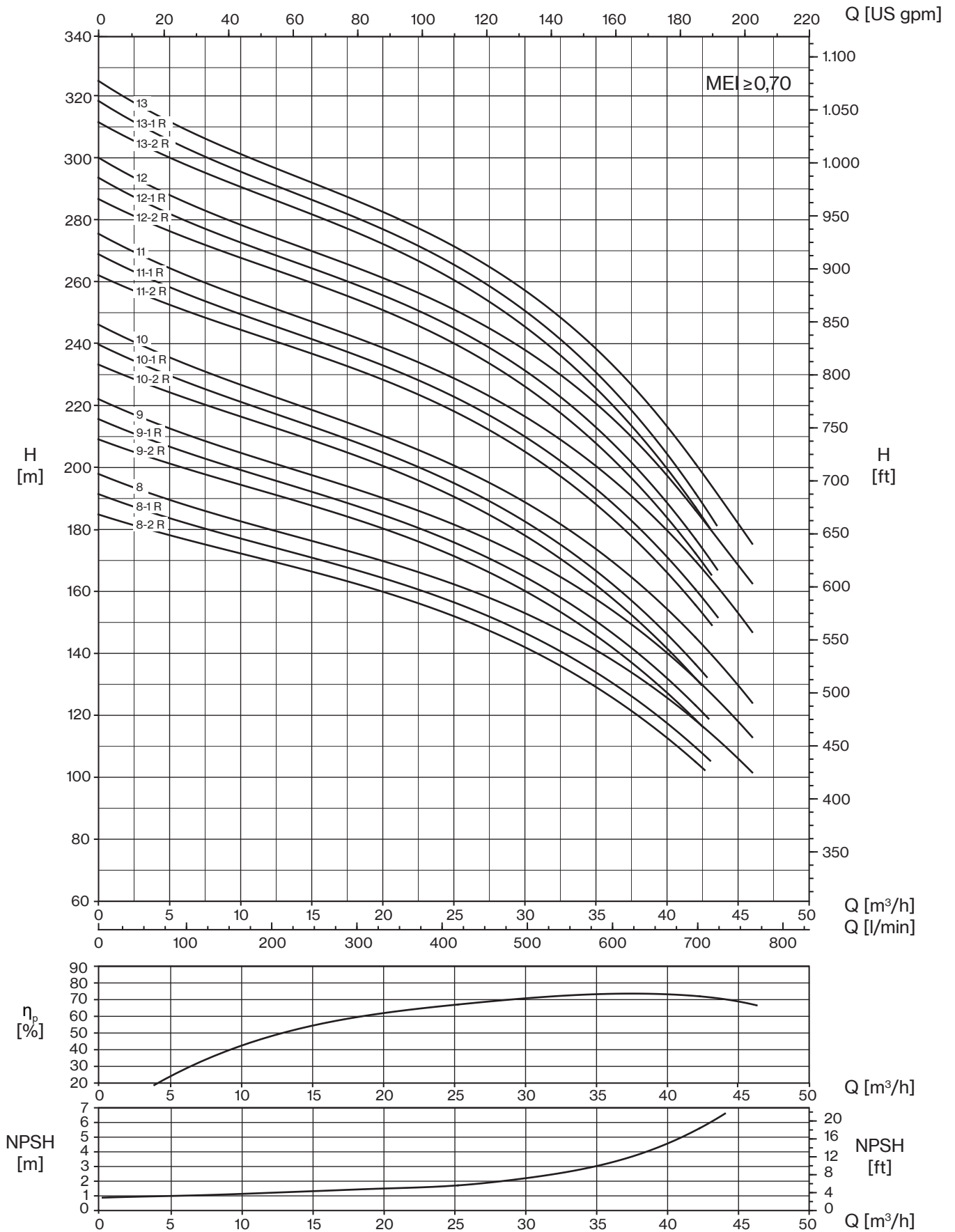

The hydraulic characteristics are guaranteed, according to ISO Standard 9906:2012, grade 3B



50 HS/HX

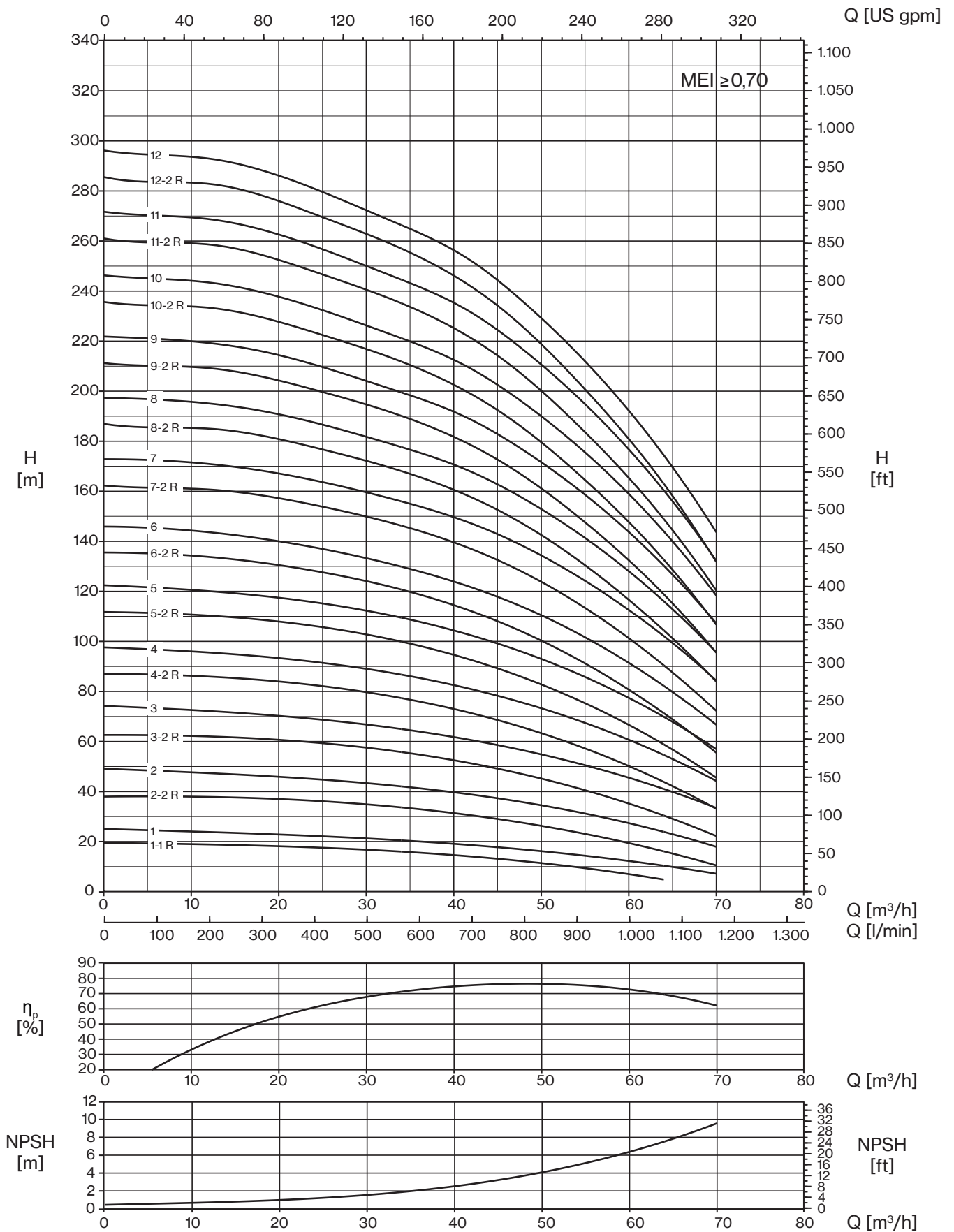

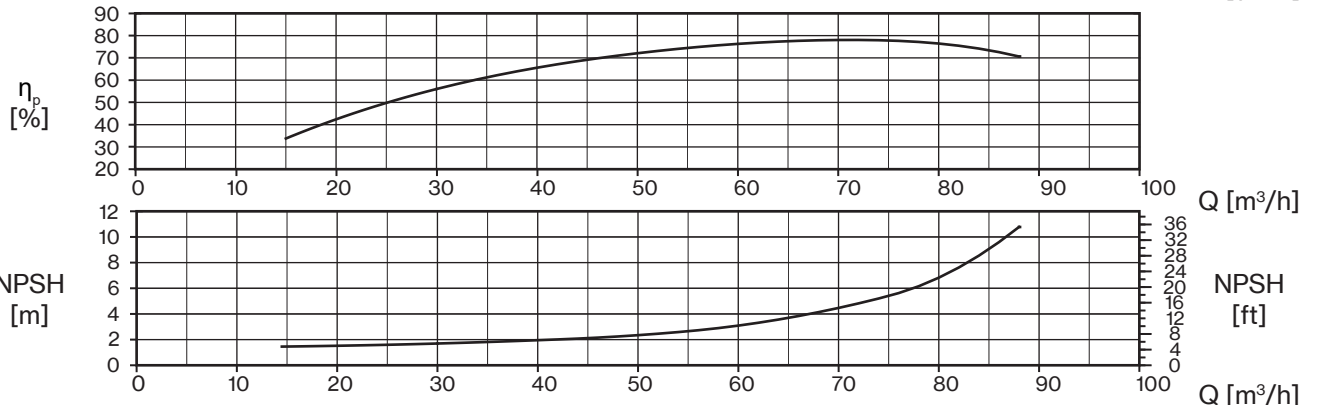
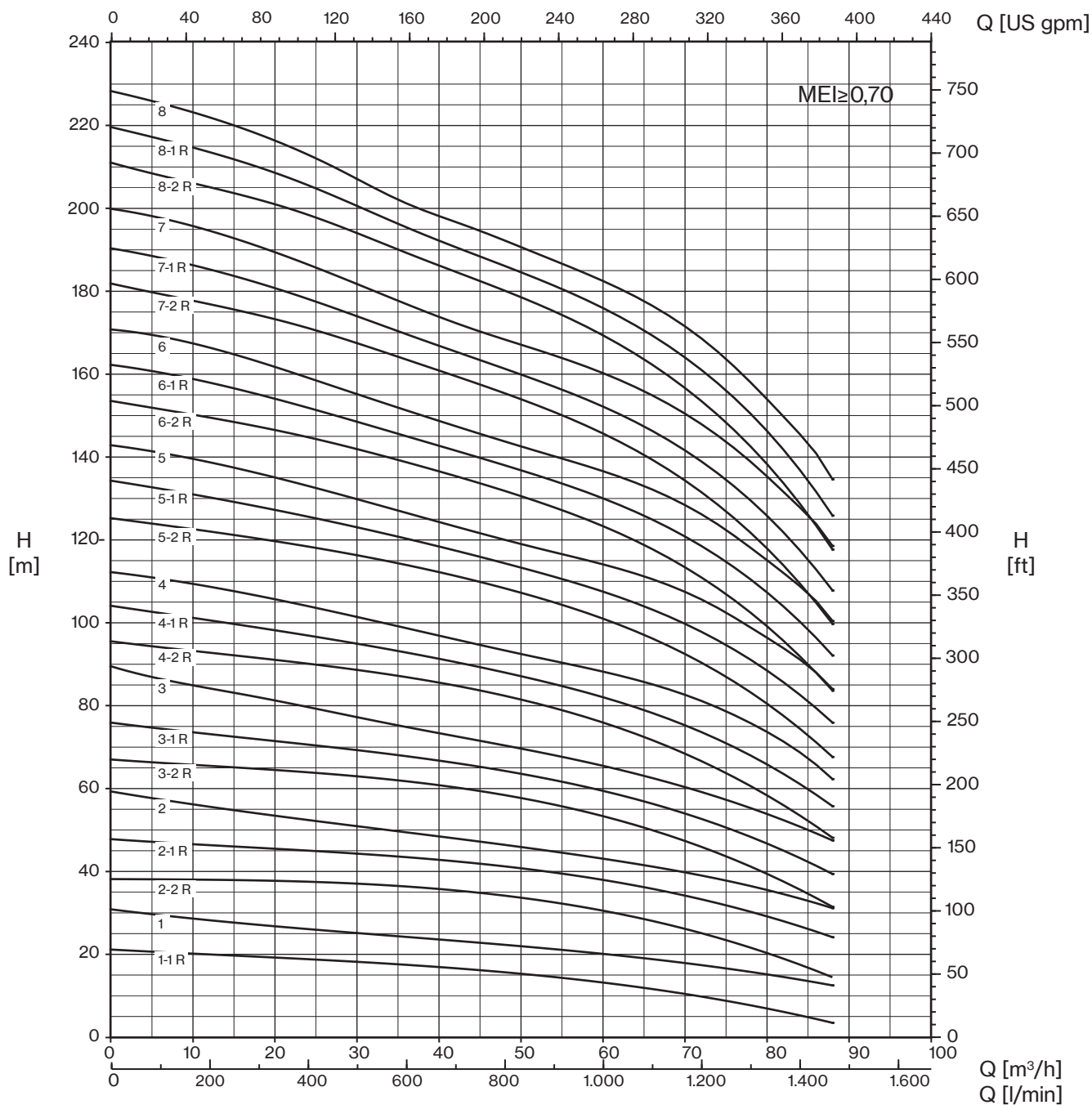

The hydraulic characteristics are guaranteed, according to ISO Standard 9906:2012, grade 3B



90 HS/HX

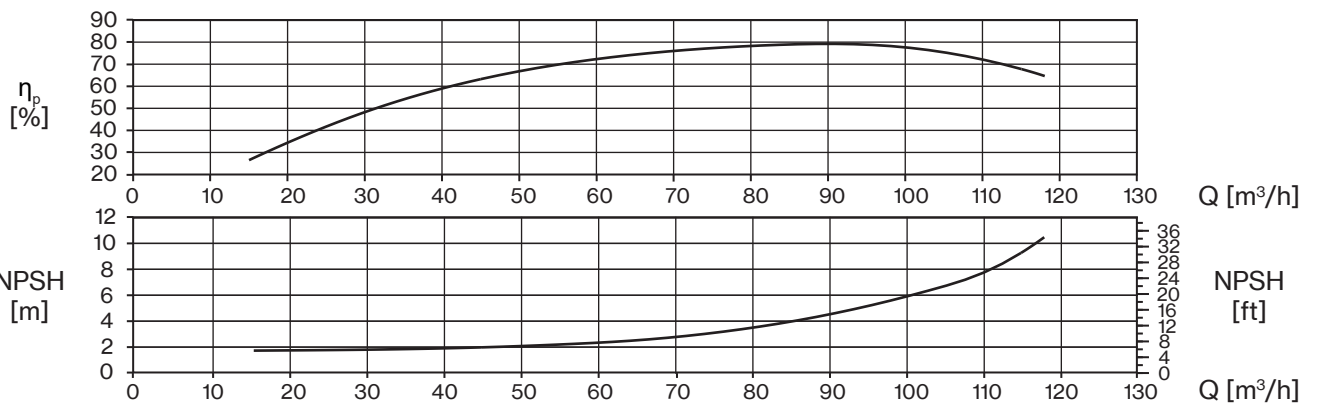
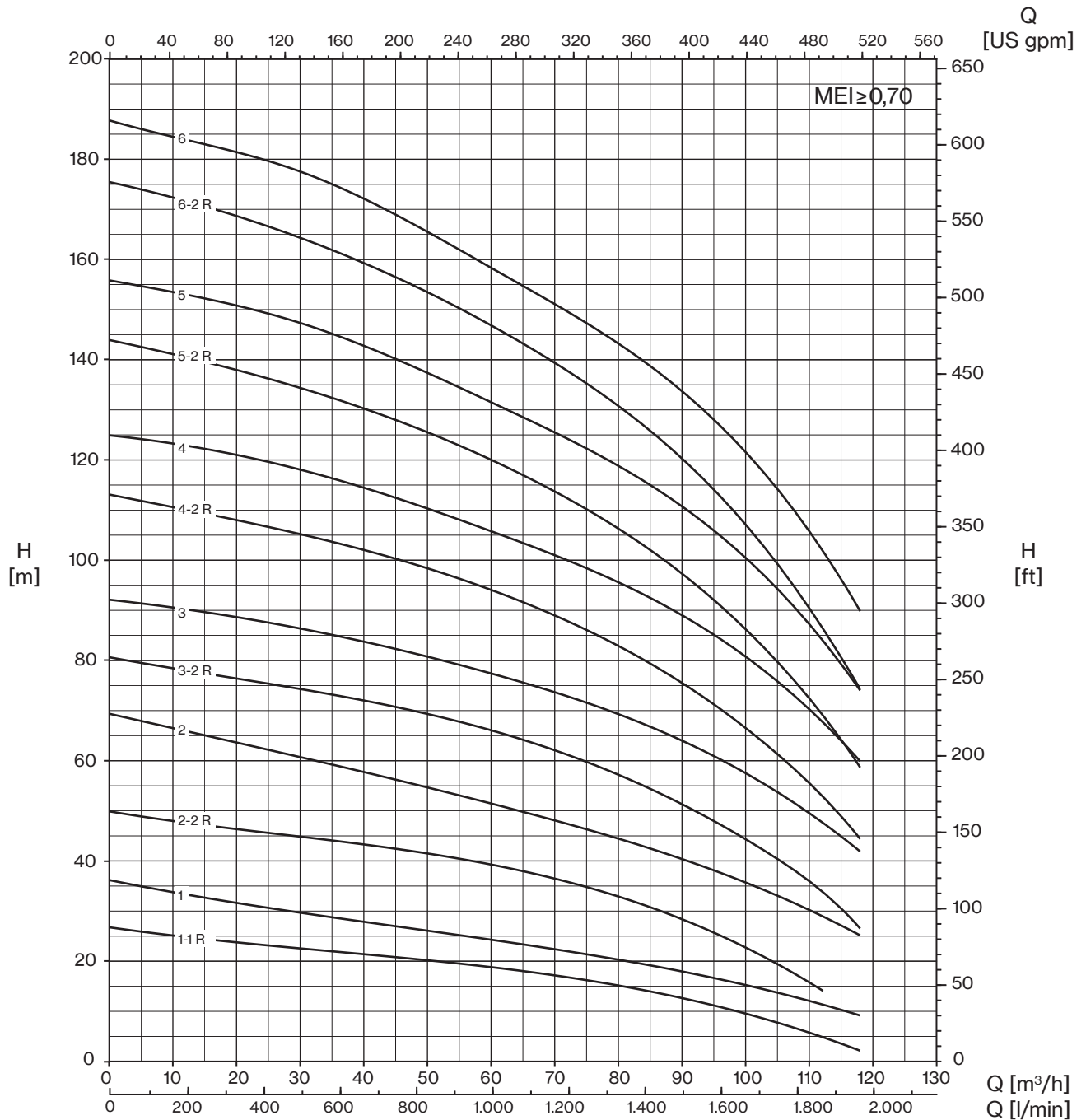

35 HS/HX

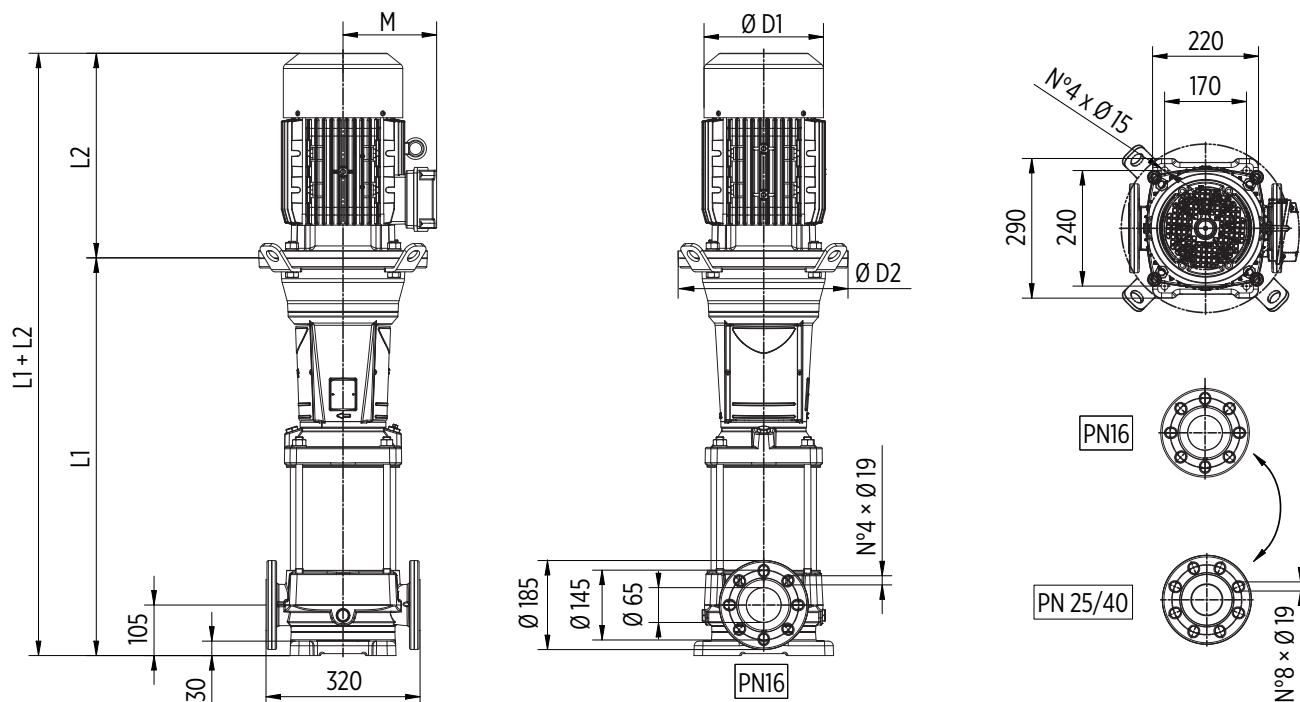

Round flanges on body type PN25/40: the pump is supplied without counterflanges (optional accessories, including bolts and joints)

TYPE	MOTOR		DIMENSIONS (mm)						Kg		
	kW	Dim	L1	L2	M	D1	D2	L1+L2	Pump	Motor	Electric Pump
P 35...-300/1T	2,2	90	431	308	145	177	170	739	48,5	26	74,5
P 35...-550/2-2RT	4	112	513	350	177	220	170	863	52	43	95
P 35...-550/2-1RT	4	112	513	350	177	220	170	863	52	43	95
P 35...-750/2T	5,5	132	724	400	197	256	300	1124	72,5	66	138,5
P 35...-750/3-2RT	5,5	132	806	400	197	256	300	1206	76,5	66	142,5
P 35...-1000/3-1RT	7,5	132	806	400	197	256	300	1206	76,5	73	149,5
P 35...-1000/3T	7,5	132	806	400	197	256	300	1206	76,5	73	149,5
P 35...-1000/4-2RT	7,5	132	888	400	197	256	300	1288	80,5	73	153,5
P 35...-1500/4-1RT	11	160	908	503	255	315	350	1411	84	120	204
P 35...-1500/4T	11	160	908	503	255	315	350	1411	84	120	204
P 35...-1500/5-2RT	11	160	991	503	255	315	350	1494	88	120	208
P 35...-1500/5-1RT	11	160	991	503	255	315	350	1494	88	120	208
P 35...-2000/5T	15	160	991	503	255	315	350	1494	88	132	220
P 35...-2000/6-2RT	15	160	1073	503	255	315	350	1576	92	132	224
P 35...-2000/6-1RT	15	160	1073	503	255	315	350	1576	92	132	224
P 35...-2000/6T	15	160	1073	503	255	315	350	1576	92	132	224
P 35...-2000/7-2RT	15	160	1155	503	255	315	350	1658	96	132	228
P 35...-2000/7-1RT	15	160	1155	503	255	315	350	1658	96	132	228
P 35...-2500/7T	18,5	160	1155	598	252	315	350	1753	96	150	246
P 35...-2500/8-2RT	18,5	160	1237	598	252	315	350	1835	100	150	250
P 35...-2500/8-1RT	18,5	160	1237	598	252	315	350	1835	100	150	250
P 35...-2500/8T	18,5	160	1237	598	252	315	350	1835	100	150	250
P 35...-3000/9-2RT	22	180	1319	620	270	360	350	1939	103,5	205	308,5
P 35...-3000/9-1RT	22	180	1319	620	270	360	350	1939	103,5	205	308,5
P 35...-3000/9T	22	180	1319	620	270	360	350	1939	103,5	205	308,5
P 35...-3000/10-2RT	22	180	1401	620	270	360	350	2021	107,5	205	312,5
P 35...-3000/10-1RT	22	180	1401	620	270	360	350	2021	107,5	205	312,5
P 35...-4000/10T	30	200	1406	661	303	400	400	2067	111	250	361
P 35...-4000/11-2RT	30	200	1488	661	303	400	400	2149	115	250	365
P 35...-4000/11-1RT	30	200	1488	661	303	400	400	2149	115	250	365
P 35...-4000/11T	30	200	1488	661	303	400	400	2149	115	250	365
P 35...-4000/12-2RT	30	200	1570	661	303	400	400	2231	119	250	369
P 35...-4000/12-1RT	30	200	1570	661	303	400	400	2231	119	250	369
P 35...-4000/12T	30	200	1570	661	303	400	400	2231	119	250	369
P 35...-4000/13-2RT	30	200	1652	661	303	400	400	2313	122,5	250	372,5
P 35...-4000/13-1RT	30	200	1652	661	303	400	400	2313	122,5	250	372,5
P 35...-4000/13T	30	200	1652	661	303	400	400	2313	122,5	250	372,5

50 HS/HX

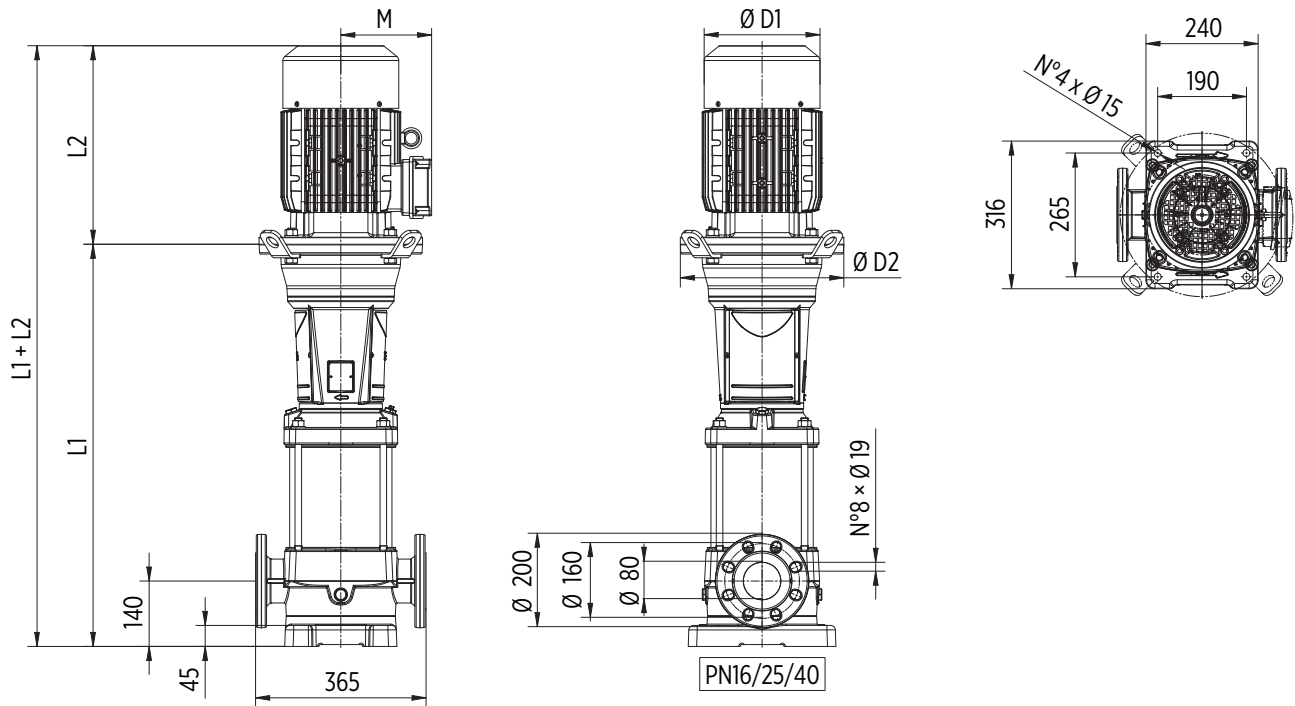

Round flanges on body type PN25/40: the pump is supplied without counterflanges (optional accessories, including bolts and joints)

TYPE	MOTOR		DIMENSIONS (mm)						Kg		
	kW	Dim	L1	L2	M	D1	D2	L1+L2	Pump	Motor	Electric Pump
P 50...-400/1-1RT	3	100	466	333	157	205	170	799	54	35	89
P 50...-550/1T	4	112	466	350	177	220	170	816	54	43	97
P 50...-750/2-2RT	5,5	132	759	400	197	256	300	1159	78,5	66	144,5
P 50...-1000/2T	7,5	132	759	400	197	256	300	1159	78,5	73	151,5
P 50...-1500/3-2RT	11	160	861	503	255	315	350	1364	85,5	120	205,5
P 50...-1500/3T	11	160	861	503	255	315	350	1364	85,5	120	205,5
P 50...-2000/4-2RT	15	160	943	503	255	315	350	1446	89,5	132	221,5
P 50...-2000/4T	15	160	943	503	255	315	350	1446	89,5	132	221,5
P 50...-2500/5-2RT	18,5	160	1026	598	252	315	350	1624	93,5	150	243,5
P 50...-2500/5T	18,5	160	1026	598	252	315	350	1624	93,5	150	243,5
P 50...-3000/6-2RT	22	180	1108	620	270	360	350	1728	97,5	205	302,5
P 50...-3000/6T	22	180	1108	620	270	360	350	1728	97,5	205	302,5
P 50...-4000/7-2RT	30	200	1195	661	303	400	400	1856	104,5	250	354,5
P 50...-4000/7T	30	200	1195	661	303	400	400	1856	104,5	250	354,5
P 50...-4000/8-2RT	30	200	1277	661	303	400	400	1938	108,5	250	358,5
P 50...-4000/8T	30	200	1277	661	303	400	400	1938	108,5	250	358,5
P 50...-5000/9-2RT	37	200	1359	661	303	400	400	2020	112,5	270	382,5
P 50...-5000/9T	37	200	1359	661	303	400	400	2020	112,5	270	382,5
P 50...-5000/10-2RT	37	200	1441	661	303	400	400	2102	116,5	270	386,5
P 50...-5000/10T	37	200	1441	661	303	400	400	2102	116,5	270	386,5
P 50...-6000/11-2RT	45	225	1523	710	312	450	450	2233	122,5	315	437,5
P 50...-6000/11T	45	225	1523	710	312	450	450	2233	122,5	315	437,5
P 50...-6000/12-2RT	45	225	1605	710	312	450	450	2315	126,5	315	441,5
P 50...-6000/12T	45	225	1605	710	312	450	450	2315	126,5	315	441,5

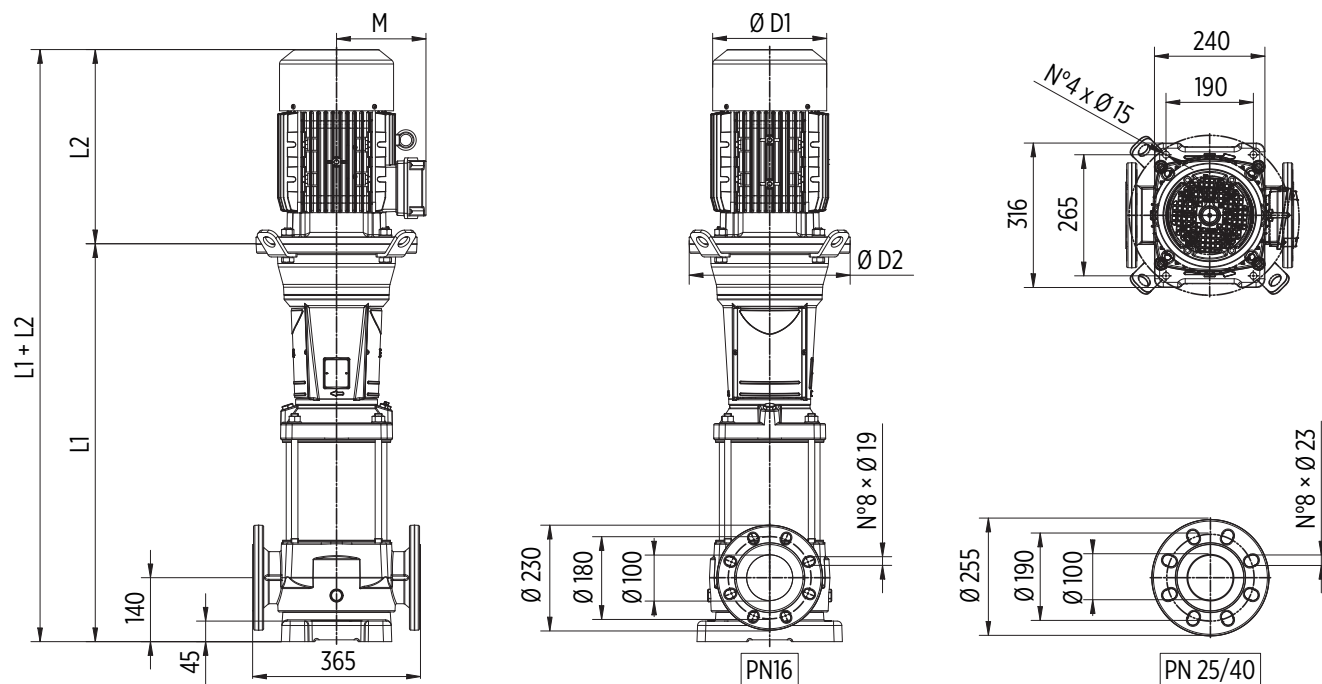

Round flanges on body type PN25/40: the pump is supplied without counterflanges (optional accessories, including bolts and joints)

TYPE	MOTOR		DIMENSIONS (mm)						Kg		
	kW	Dim	L1	L2	M	D1	D2	L1+L2	Pump	Motor	Electric Pump
P 75...-550/1-1RT	4	112	526	350	177	220	170	876	60	43	103
P 75...-750/1T	5,5	132	737	400	197	256	300	1137	80,5	66	146,5
P 75...-1000/2-2RT	7,5	132	829	400	197	256	300	1229	85	73	158
P 75...-1500/2-1RT	11	160	849	503	255	315	350	1352	88,5	120	208,5
P 75...-1500/2T	11	160	849	503	255	315	350	1352	88,5	120	208,5
P 75...-2000/3-2RT	15	160	941	503	255	315	350	1444	93	132	225
P 75...-2000/3-1RT	15	160	941	503	255	315	350	1444	93	132	225
P 75...-2500/3T	18,5	160	941	598	252	315	350	1539	93	150	243
P 75...-2500/4-2RT	18,5	160	1033	598	252	315	350	1631	97,5	150	247,5
P 75...-3000/4-1RT	22	180	1033	620	270	360	350	1653	97	205	302
P 75...-3000/4T	22	180	1033	620	270	360	350	1653	97	205	302
P 75...-4000/5-2RT	30	200	1131	661	303	400	400	1792	105	250	355
P 75...-4000/5-1RT	30	200	1131	661	303	400	400	1792	105	250	355
P 75...-4000/5T	30	200	1131	661	303	400	400	1792	105	250	355
P 75...-4000/6-2RT	30	200	1223	661	303	400	400	1884	109,5	250	359,5
P 75...-5000/6-1RT	37	200	1223	661	303	400	400	1884	109,5	270	379,5
P 75...-5000/6T	37	200	1223	661	303	400	400	1884	109,5	270	379,5
P 75...-5000/7-2RT	37	200	1315	661	303	400	400	1976	113,5	270	383,5
P 75...-5000/7-1RT	37	200	1315	661	303	400	400	1976	113,5	270	383,5
P 75...-6000/7T	45	225	1315	710	312	450	450	2025	116	315	431
P 75...-6000/8-2RT	45	225	1407	710	312	450	450	2117	120,5	315	435,5
P 75...-6000/8-1RT	45	225	1407	710	312	450	450	2117	120,5	315	435,5
P 75...-6000/8T	45	225	1407	710	312	450	450	2117	120,5	315	435,5

90 HS/HX

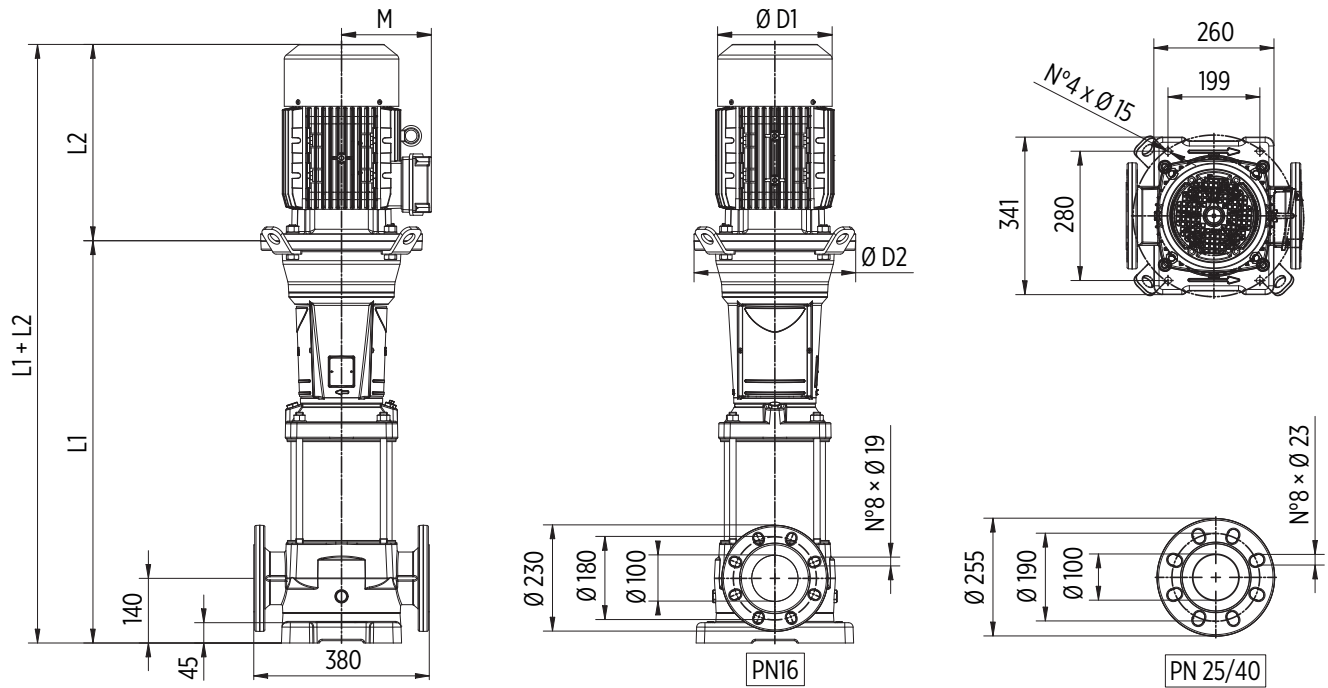

Round flanges on body type PN25/40: the pump is supplied without counterflanges (optional accessories, including bolts and joints)

TYPE	MOTOR		DIMENSIONS (mm)						Kg		
	kW	Dim	L1	L2	M	D1	D2	L1+L2	Pump	Motor	Electric Pump
P 90...-750/1-1RT	5,5	132	737	400	197	256	300	1137	82	66	148
P 90...-1000/1T	7,5	132	737	400	197	256	300	1137	82	73	155
P 90...-1500/2-2RT	11	160	849	503	255	315	350	1352	89	120	209
P 90...-2000/2T	15	160	849	503	255	315	350	1352	89	132	221
P 90...-2500/3-2RT	18,5	160	941	598	252	315	350	1539	93	150	243
P 90...-3000/3T	22	180	941	620	270	360	350	1561	92,5	205	297,5
P 90...-4000/4-2RT	30	200	1038	661	303	400	400	1699	99,5	250	349,5
P 90...-4000/4T	30	200	1038	661	303	400	400	1699	99,5	250	349,5
P 90...-5000/5-2RT	37	200	1131	661	303	400	400	1792	103	270	373
P 90...-5000/5T	37	200	1131	661	303	400	400	1792	103	270	373
P 90...-6000/6-2RT	45	225	1223	710	312	450	450	1933	109	315	424
P 90...-6000/6T	45	225	1223	710	312	450	450	1933	109	315	424

PLUS HS-HX Serie-Mechanical seal and bearings

CARTRIDGE MECHANICAL SEAL	PUMP MODEL	SHAFT		STANDARD MATERIAL	OPTIONAL		
					V	2	2V
	P18-100/1T, P18-200/2T, P18-300/3T, P18-400/4T, P18-550/5T, P18-750/6T, P18-750/7T, P18-1000/8T, P18-1000/9T, P18-1500/10T, P18-1500/11T, P18-1500/12T, P18-1500/13T, P18-1500/14T, P18-2000/15T, P18-2000/16T, P18-2000/17T, P22-150/1T, P22-300/2T, P22-400/3T, P22-550/4T, P22-750/5T, P22-1000/6T, P22-1000/7T, P22-1500/8T, P22-1500/9T, P22-1500/10T, P22-2000/11T, P22-2000/12T, P22-2000/13T	16mm	Rotating face Stationary face Elastomer	SiC Graphite EPDM	SiC Graphite FKM	SiC SiC EPDM	SiC SiC FKM
	P35-300/1T, P35-550/2-2RT, P35-550/2-1RT, P35-750/2T, P35-750/3-2RT, P35-1000/3-1RT, P35-1000/3T, P35-1000/4-2RT, P35-1500/4-1RT, P35-1500/4T, P35-1500/5-2RT, P35-1500/5-1RT, P35-2000/5T, P35-2000/6-2RT, P35-2000/6-1RT, P35-2000/6T, P35-2000/7-2RT, P35-2000/7-1RT, P35-2500/7T, P35-2500/8-2RT, P35-2500/8-1RT, P35-2500/8T, P35-3000/9-2RT, P35-3000/9-1RT, P35-3000/9T, P35-3000/10-2RT, P35-3000/10-1RT, P35-4000/10T, P35-4000/11-2RT, P35-4000/11-1RT, P35-4000/11T, P35-4000/12-2RT, P35-4000/12-1RT, P35-4000/12T, P35-4000/13-2RT, P35-4000/13-1RT, P35-4000/13T, P50-400/1-1RT, P50-550/1T, P50-750/2-2RT, P50-1000/2T, P50-1500/3-2RT, P50-1500/3T, P50-2000/4-2RT, P50-2000/4T, P50-2500/5-2RT, P50-2500/5T, P50-3000/6-2RT, P50-3000/6T, P50-4000/7-2RT, P50-4000/7T, P50-4000/8-2RT, P50-4000/8T, P50-5000/9-2RT, P50-5000/9T, P50-5000/10-2RT, P50-5000/10T, P50-6000/11-2RT, P50-6000/11T, P50-6000/12-2RT, P50-6000/12T, P75-550/1-1RT, P75-750/1T, P75-1000/2-2RT, P75-1500/2-1RT, P75-1500/2T, P75-2000/3-2RT, P75-2000/3-1RT, P75-2500/3T, P75-2500/4-2RT, P75-3000/4-1RT, P75-3000/4T, P75-4000/5-2RT, P75-4000/5-1RT, P75-4000/5T, P75-4000/6-2RT, P75-5000/6-1RT, P75-5000/6T, P75-5000/7-2RT, P75-5000/7-1RT, P75-6000/7T, P75-6000/8-2RT, P75-6000/8-1RT, P75-6000/8T, P90-750/1-1RT, P90-1000/1T, P90-1500/2-2RT, P90-2000/2T, P90-2500/3-2RT, P90-3000/3T, P90-4000/4-2RT, P90-4000/4T, P90-5000/5-2RT, P90-5000/5T, P90-6000/6-2RT, P90-6000/6T	22mm / Balanced seal	Rotating face Stationary face Elastomer	SiC Graphite EPDM	SiC Graphite FKM	SiC SiC EPDM	SiC SiC FKM

BEARINGS	PUMP MODEL	PUMP THRUST BEARING		MOTOR BEARING	
	P18-100/1T, P22-150/1T	-	-	6204-ZZ C3	6204-ZZ C3
	P18-200/2T, P18-300/3T, P22-300/2T, P35-300/1T	-	-	6205-ZZ C3	6205-ZZ C3
	P18-400/4T, P18-550/5T, P22-400/3T, P22-550/4T, P35-550/2-2RT, P35-550/2-1RT, P50-400/1-1RT, P50-550/1T, P75-550/1-1RT	-	-	6206-ZZ C3	6206-ZZ C3
	P18-750/6T, P18-750/7T, P18-1000/8T, P18-1000/9T, P22-750/5T, P22-1000/6T, P22-1000/7T, P35-750/2T, P35-750/3-2RT, P35-1000/3-1RT, P35-1000/3T, P35-1000/4-2RT, P50-750/2-2RT, P50-1000/2T, P75-750/1T, P75-1000/2-2RT, P90-750/1-1RT, P90-1000/1T			6208-ZZ C3	6208-ZZ C3
	P18-1500/10T, P18-1500/11T, P18-1500/12T, P18-1500/13T, P18-1500/14T, P18-2000/15T, P18-2000/16T, P18-2000/17T, P22-1500/8T, P22-1500/9T, P22-1500/10T, P22-2000/11T, P22-2000/12T, P22-2000/13T, P22-2000/14T, P22-2500/15T, P22-2500/16T, P22-2500/17T, P35-1500/4-1RT, P35-1500/4T, P35-1500/5-2RT, P35-1500/5-1RT, P50-1500/3-2RT, P50-1500/3T, P75-1500/2-1RT, P75-1500/2T, P90-1500/2-2RT	6212 ZZ	-		
	P35-2000/5T, P35-2000/6-2RT, P35-2000/6-1RT, P35-2000/6T, P35-2000/7-2RT, P35-2000/7-1RT, P35-2500/7T, P35-2500/8-2RT, P35-2500/8-1RT, P35-2500/8T, P50-2000/4-2RT, P50-2000/4T, P50-2500/5-2RT, P50-2500/5T, P75-2000/3-2RT, P75-2000/3-1RT, P75-2500/3T, P75-2500/4-2RT, P90-2000/2T, P90-2500/3-2RT	6212 ZZ	7212 BEP		
	P35-3000/9-2RT, P35-3000/9-1RT, P35-3000/9T, P35-3000/10-2RT, P35-3000/10-1RT, P50-3000/6-2RT, P50-3000/6T, P75-3000/4-1RT, P75-3000/4T, P90-3000/3T			6311-ZZ C3	6311-ZZ C3
	P35-4000/10T, P35-4000/11-2RT, P35-4000/11-1RT, P35-4000/11T, P35-4000/12-2RT, P35-4000/12-1RT, P35-4000/12T, P35-4000/13-2RT, P35-4000/13-1RT, P35-4000/13T, P50-4000/7-2RT, P50-4000/7T, P50-4000/8-2RT, P50-4000/8T, P50-5000/9-2RT, P50-5000/9T, P50-5000/10-2RT, P50-5000/10T, P75-4000/5-2RT, P75-4000/5-1RT, P75-4000/5T, P75-4000/6-2RT, P75-5000/6-1RT, P75-5000/6T, P75-5000/7-2RT, P75-5000/7-1RT, P90-4000/4-2RT, P90-4000/4T, P90-5000/5-2RT, P90-5000/5T	6214 ZZ	7214 BEP	6312-ZZ C3	6312-ZZ C3
P50-6000/11-2RT, P50-6000/11T, P50-6000/12-2RT, P50-6000/12T, P75-6000/7T, P75-6000/8-2RT, P75-6000/8-1RT, P75-6000/8T, P90-6000/6-2RT, P90-6000/6T			6313-ZZ C3	6313-ZZ C3	

PLUS V/L/H + VSD

Vertical booster pump with variable speed drive

PLUS V



EPIC / EPIC-A

IPFC

PLUS L



EPIC / EPIC-A

IPFC

PLUS H



EPIC / EPIC-A

IPFC

DESCRIPTION

Horizontal pump of PLUS series provided with variable speed drive EPIC, EPIC-A or IPFC. This booster pump assures a desired pressure regardless of changes on flow demand making it suitable for low or missing pressure in residential systems and industrial applications. It is required the installation of a membrane tank downstream the system.

FEATURES

- EPIC, EPIC-A or IPFC variable speed drive
- Three-phase vertical pump of PLUS series
- Pressure sensor wired to the vsd
- Cable with plug for EPIC vsd only

FUNCTIONING

If the pressure in the network drops the pump will start and gradually speeds up to provide with the set pressure. When the water demand decreases, the pressure will rise causing the pump speed to slow down and eventually to stop the pump if demand ceases. The pump will remain on standby waiting to start at the next water demand.

SELECTION

The next table shows the vertical PLUS pump models available for the assembly with EPIC, EPIC-A or IPFC. Consult the catalog at the PLUS series for pump specifics and characteristic curves.

P3SL /A 100/5 T -304 3×400-50

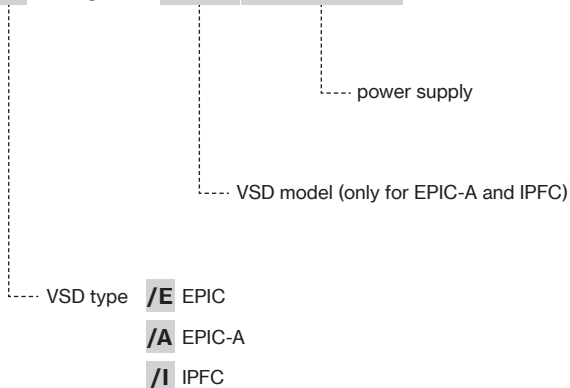

3- PUMP								VSD TYPE							
TYPE		VERSION						Power supply							
		V	SV	L	SL/SLX	LG	SLG/SLGX	1-230V		3-400V					
P 3	100/5T	■	■	■	■	-	-	EPIC	IPFC 109	EPIC-A 304	IPFC 306				
	120/6T	■	■	■	■	-	-								
	150/7T	■	■	■	■	-	-								
	180/8T	■	■	■	■	-	-								
	200/9T	■	■	■	■	-	-								
	250/10T	■	■	■	■	-	-								
	280/11T	-	■	-	■	-	-		-	IPFC 114	EPIC-A 306				
	300/12T	■	■	■	■	-	-								
	350/14T	-	-	-	-	-	■								
	380/16T	-	-	-	-	-	■								
	400/18T	-	-	-	-	-	■								
450/20T	-	-	-	-	-	■	-	-	EPIC-A 309	IPFC 309					
P 5	120/4T	■	■	■	■	-	-	EPIC	IPFC 109	EPIC-A 304	IPFC 306				
	150/5T	■	■	■	■	-	-								
	180/6T	■	■	■	■	-	-								
	200/7T	■	■	■	■	-	-								
	250/8T	■	■	■	■	-	-								
	280/9T	-	■	-	■	-	-					-	IPFC 114	EPIC-A 306	
	300/10T	■	■	■	■	-	-								
	350/11T	■	■	■	■	-	-								
	380/12T	■	■	■	■	-	-								
	400/14T	-	-	-	-	-	■		-	-	EPIC-A 309				IPFC 309
	450/16T	-	-	-	-	-	■		-	-	EPIC-A 314	IPFC 311			
550/18T	-	-	-	-	-	■	-	-	-	-					
600/20T	-	-	-	-	-	■	-	-	-	-					
P 7	180/4T	■	■	■	■	-	-	EPIC	IPFC 109	EPIC-A 304	IPFC 306				
	250/5T	■	■	■	■	-	-								
	300/6T	■	■	■	■	-	-		-	IPFC 114	EPIC-A 306				
	350/7T	■	■	■	■	-	-								
	400/8T	■	■	■	■	-	-								
	450/9T	■	■	■	■	-	-								
	550/10T	■	■	■	■	-	-								
	750/12T	-	-	-	-	-	■					-	-	-	
	800/14T	-	-	-	-	-	■					-	-	EPIC-A 314	IPFC 314
	900/16T	-	-	-	-	-	■					-	-	-	
	950/18T	-	-	-	-	-	■					-	-	-	
1000/20T	-	-	-	-	-	■	-	-	EPIC-A 318	IPFC 318					
P 9	200/4T	■	■	■	■	-	-	EPIC	IPFC 109	EPIC-A 304	IPFC 306				
	250/5T	■	■	■	■	-	-								
	300/6T	■	■	■	■	-	-		-	IPFC 114	EPIC-A 306				
	400/7T	■	■	■	■	-	-								
	450/8T	■	■	■	■	-	-								
	500/9T	■	■	■	■	-	-								
	550/10T	■	■	■	■	-	-								
	750/12T	-	-	-	-	-	■					-	-	EPIC-A 309	IPFC 309
	800/14T	-	-	-	-	-	■					-	-	EPIC-A 314	IPFC 314
	900/16T	-	-	-	-	-	■					-	-	-	
	950/18T	-	-	-	-	-	■					-	-	-	
1000/20T	-	-	-	-	-	■	-	-	EPIC-A 318	IPFC 318					

PLUS+VSD

		3- PUMP							VSD TYPE			
TYPE		VERSION							Power supply			
		V	SV	L	SL/ SLX	LG	HS	HX	1-230V		3-400V	
P 18	100/1T	-	-	-	-	-	-	■	EPIC	IPFC 109	EPIC-A 304	IPFC 306
	200/2T	-	-	-	-	-	-	■				
	300/3T	-	-	-	-	-	-	■	IPFC 114	EPIC-A 306		
	250/3T	■	■	■	■	-	-	-				
	400/4T	-	-	-	-	-	-	■	-	-	EPIC-A 309	IPFC 309
	450/5T	■	■	■	■	-	-	-				
	550/5T	-	-	-	-	-	-	■			EPIC-A 314	IPFC 311
	550/6T	■	■	■	■	-	-	-				
	750/6T	-	-	-	-	-	-	■				
	750/7T	-	-	-	-	-	-	■				
	750/8T	■	■	■	■	-	-	-			IPFC 314	
	1000/8T	-	-	-	-	-	-	■				
	1000/9T	-	-	-	-	-	-	■			EPIC-A 318	IPFC 318
	900/9T	■	■	■	■	-	-	-				
	920/10T	-	-	-	-	■	-	-				
	1000/11T	-	-	-	-	■	-	-				
	1500/10T	-	-	-	-	-	-	■				
	1500/11T	-	-	-	-	-	-	■				
	1500/12T	-	-	-	-	-	-	■				
	1500/13T	-	-	-	-	-	-	■				
1500/14T	-	-	-	-	-	-	■					
2000/15T	-	-	-	-	-	-	■					
2000/16T	-	-	-	-	-	-	■	EPIC-A 325	IPFC 325			
2000/17T	-	-	-	-	-	-	■					
P 22	200/1T	-	-	-	-	-	-	■	EPIC	IPFC 109	EPIC-A 304	IPFC 306
	300/2T	-	-	-	-	-	-	■				
	400/3T	-	-	-	-	-	-	■	IPFC 114	EPIC-A 306		
	550/4T	-	-	-	-	-	-	■				
	750/5T	-	-	-	-	-	-	■	EPIC-A 309	IPFC 309		
	1000/6T	-	-	-	-	-	-	■				
	1000/7T	-	-	-	-	-	-	■	EPIC-A 314	IPFC 311		
	1500/8T	-	-	-	-	-	-	■				
	1500/9T	-	-	-	-	-	-	■	IPFC 314			
	1500/10T	-	-	-	-	-	-	■				
	2000/11T	-	-	-	-	-	-	■	EPIC-A 318	IPFC 318		
	2000/12T	-	-	-	-	-	-	■				
	2000/13T	-	-	-	-	-	-	■				
	2000/14T	-	-	-	-	-	-	■				
	2000/15T	-	-	-	-	-	-	■	EPIC-A 325	IPFC 325		
	2000/16T	-	-	-	-	-	-	■				
	2000/17T	-	-	-	-	-	-	■				
	2000/18T	-	-	-	-	-	-	■				
2000/19T	-	-	-	-	-	-	■					
2000/20T	-	-	-	-	-	-	■					
2000/21T	-	-	-	-	-	-	■	EPIC-A 325	IPFC 325			
2000/22T	-	-	-	-	-	-	■					
2000/23T	-	-	-	-	-	-	■	EPIC-A 330	IPFC 330			
2000/24T	-	-	-	-	-	-	■					
2000/25T	-	-	-	-	-	-	■	EPIC-A 338	-			
2000/26T	-	-	-	-	-	-	■					
2000/27T	-	-	-	-	-	-	■	EPIC-A 338	-			
2000/28T	-	-	-	-	-	-	■					

		3- PUMP							VSD TYPE			
TYPE		VERSION							Power supply			
		V	SV	L	SL/SLX	LG	HS	HX	1-230V	3-400V		
P 35	300/1T	-	-	-	-	-	■	■	-	IPFC 114	EPIC-A 306	IPFC 306
	550/2-2RT	-	-	-	-	-	■	■			EPIC-A 309	IPFC 309
	550/2-1RT	-	-	-	-	-	■	■			EPIC-A 314	IPFC 311
	750/2T	-	-	-	-	-	■	■				IPFC 314
	750/3-2RT	-	-	-	-	-	■	■			EPIC-A 318	IPFC 318
	1000/3-1RT	-	-	-	-	-	■	■				EPIC-A 325
	1000/3T	-	-	-	-	-	■	■			EPIC-A 330	
	1000/4-2RT	-	-	-	-	-	■	■				EPIC-A 338
	1500/4-1RT	-	-	-	-	-	■	■				
	1500/4T	-	-	-	-	-	■	■			EPIC-A 344	
	1500/5-2RT	-	-	-	-	-	■	■				
	1500/5-1RT	-	-	-	-	-	■	■			EPIC-A 338	
	2000/5T	-	-	-	-	-	■	■				
	2000/6-2RT	-	-	-	-	-	■	■			EPIC-A 330	IPFC 330
	2000/6-1RT	-	-	-	-	-	■	■				
	2000/6T	-	-	-	-	-	■	■			EPIC-A 338	
	2000/7-2RT	-	-	-	-	-	■	■				
	2000/7-1RT	-	-	-	-	-	■	■			EPIC-A 344	
	2500/7T	-	-	-	-	-	■	■				
	2500/8-2RT	-	-	-	-	-	■	■			EPIC-A 338	
2500/8-1RT	-	-	-	-	-	■	■					
2500/8T	-	-	-	-	-	■	■	EPIC-A 344				
3000/9-2RT	-	-	-	-	-	■	■					
3000/9-1RT	-	-	-	-	-	■	■	EPIC-A 338				
3000/9T	-	-	-	-	-	■	■					
3000/10-2RT	-	-	-	-	-	■	■	EPIC-A 344				
3000/10-1RT	-	-	-	-	-	■	■					
4000/10T	-	-	-	-	-	■	■					
P 50	400/1-1RT	-	-	-	-	-	■	■	-	IPFC 114	EPIC-A 306	IPFC 306
	550/1T	-	-	-	-	-	■	■			EPIC-A 309	IPFC 309
	750/2-2RT	-	-	-	-	-	■	■			EPIC-A 314	IPFC 311
	1000/2T	-	-	-	-	-	■	■			EPIC-A 318	IPFC 318
	1500/3-2RT	-	-	-	-	-	■	■			EPIC-A 325	IPFC 325
	1500/3T	-	-	-	-	-	■	■			EPIC-A 330	IPFC 330
	2000/4-2RT	-	-	-	-	-	■	■			EPIC-A 338	
	2000/4T	-	-	-	-	-	■	■			EPIC-A 344	
	2500/5-2RT	-	-	-	-	-	■	■			EPIC-A 338	
	2500/5T	-	-	-	-	-	■	■			EPIC-A 344	
	3000/6-2RT	-	-	-	-	-	■	■			EPIC-A 338	
	3000/6T	-	-	-	-	-	■	■			EPIC-A 344	
	4000/7-2RT	-	-	-	-	-	■	■			EPIC-A 338	
								EPIC-A 344				
P 75	550/1-1RT	-	-	-	-	-	■	■	-	-	EPIC-A 309	IPFC 309
	750/1T	-	-	-	-	-	■	■			EPIC-A 314	IPFC 311
	1000/2-2RT	-	-	-	-	-	■	■			EPIC-A 318	IPFC 318
	1500/2-1RT	-	-	-	-	-	■	■			EPIC-A 325	IPFC 325
	1500/2T	-	-	-	-	-	■	■			EPIC-A 330	IPFC 330
	2000/3-2RT	-	-	-	-	-	■	■			EPIC-A 338	
	2000/3-1RT	-	-	-	-	-	■	■			EPIC-A 344	
	2500/3T	-	-	-	-	-	■	■			EPIC-A 338	
	2500/4-2RT	-	-	-	-	-	■	■			EPIC-A 344	
	3000/4-1RT	-	-	-	-	-	■	■			EPIC-A 338	
	3000/4T	-	-	-	-	-	■	■			EPIC-A 344	
4000/5-2RT	-	-	-	-	-	■	■	EPIC-A 338				
								EPIC-A 344				
P 90	750/1-1RT	-	-	-	-	-	■	■	-	-	EPIC-A 314	IPFC 311
	1000/1T	-	-	-	-	-	■	■			EPIC-A 318	IPFC 318
	1500/2-2RT	-	-	-	-	-	■	■			EPIC-A 325	IPFC 325
	2000/2T	-	-	-	-	-	■	■			EPIC-A 330	IPFC 330
	2500/3-2RT	-	-	-	-	-	■	■			EPIC-A 338	
3000/3T	-	-	-	-	-	■	■	EPIC-A 344				