

Drainage pumps for charged liquids with set-back Vortex type impeller for civil and industrial applications; specifically designed for very heavy use; available in the mobile or permanent versions with coupling feet.



Construction features

Painting	cataphoresis
Pump body	cast iron
	Impeller cast iron
Mechanical seal	double seal with oil barrier; silicon carbide on pump side, ceramic-graphite on motor side
Motor shaft	stainless steel AISI 304
Free passage	Ø max 50 mm (160÷310; 750-1000) Ø max 45 mm (400-550)
Max submergence	20 m
Liquid temperature	0 - 40 °C
Cable	H07 RN8F, 10 m
Bolts	A2 stainless steel
Foot support	galvanized iron
Gaskets	NBR rubber

Motor

2 Poles induction motor	3- 230V - 50Hz 3- 400V - 50Hz 3- 230/400V - 50Hz 3- 400/690V - 50Hz
	1- 230V - 50Hz required run capacitor (35µF for 1,5HP model, 50µF for 2HP model)
Insulation class	F
Protection degree	IPX8

TYPE	LOTS			
	TRUCK		CONTAINER	
	PALLET (cm)	N° pumps	PALLET (cm)	N° pumps
FV 160÷310	85×110×145	18	85×110×190	27
FV 400-550T	85×110×170	12	85×110×170	12
FV 750-1000T	100×120×190	12	100×120×190	12

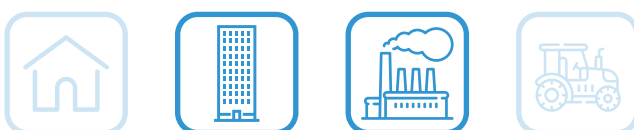
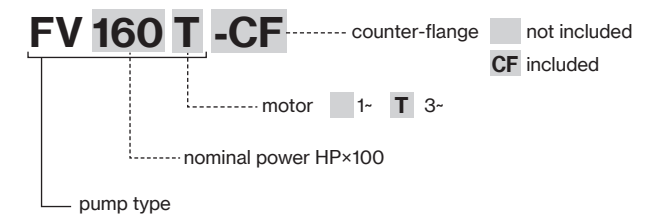

Q [imp g.p.m]
Q [US g.p.m.]

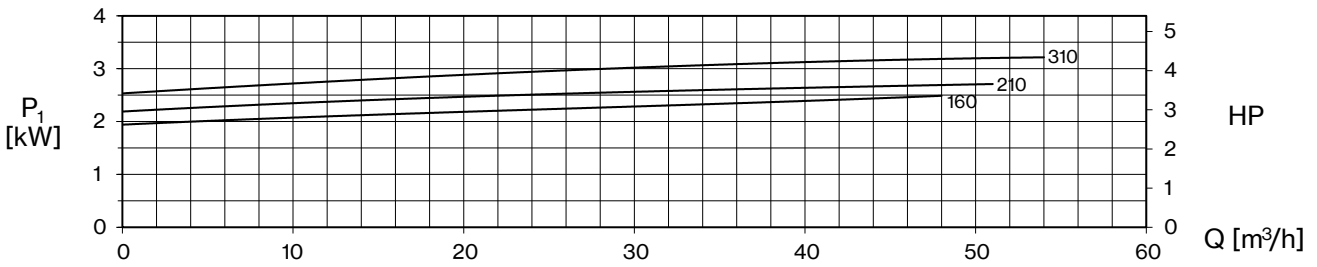
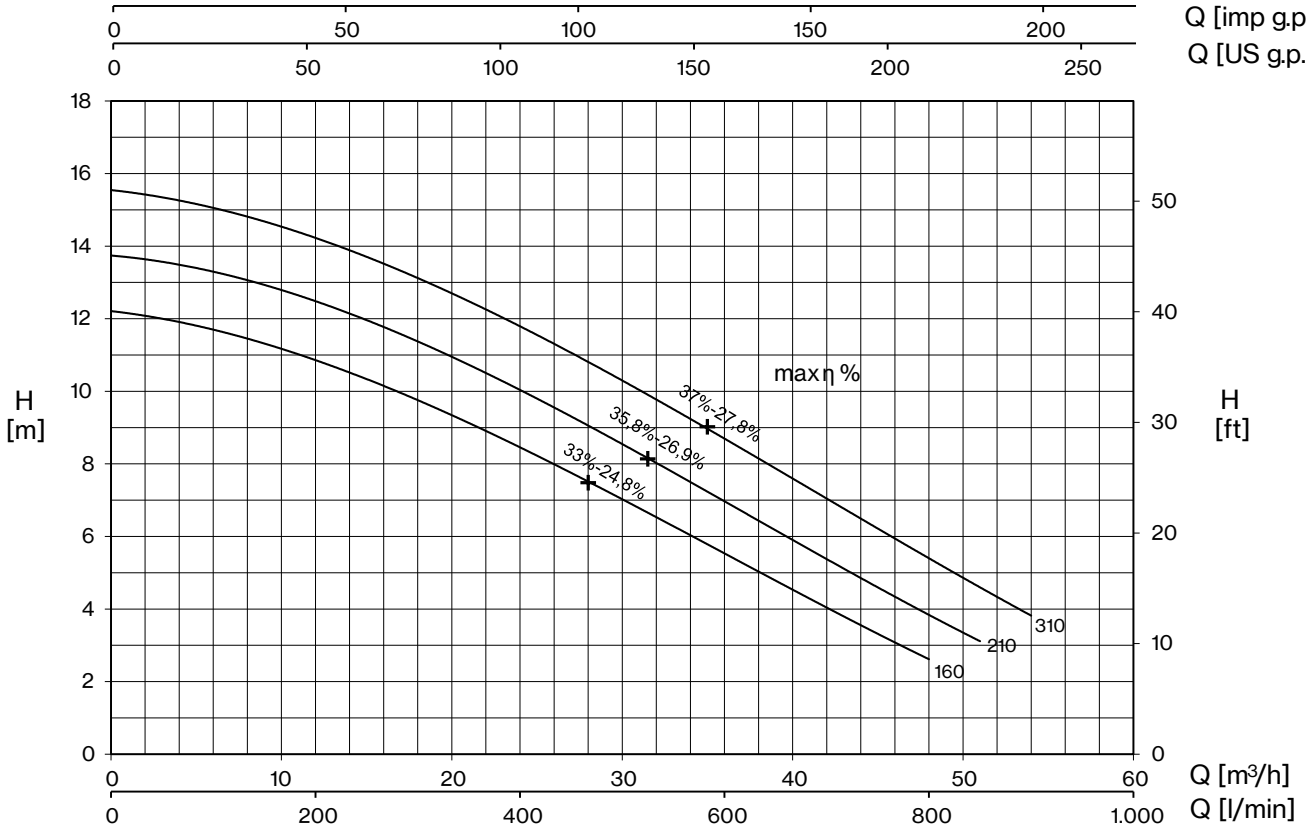

TYPE		AMPERE				
1~	3~	230V 50 Hz	3~ 230V 50 Hz (*)	3~ 400V 50 Hz	230/400 V 50 Hz λ / Δ (*)	400/690 V 50 Hz λ / Δ
FV 160	FV 160T	11,3	7,1	4,1	-	-
FV 210	FV 210T	12,6	8,7	5,0	-	-
-	FV 310T	-	9,9	5,7	-	-

+ max η %

max hydraulic efficiency and respective total efficiency

(*) no standard execution

TYPE		P2		P1 (kW)		Q (m³/h - l/min)							
1~	3~	HP	kW	1~	3~	0	12	24	36	42	48	51	54
						0	200	400	600	700	800	850	900
						H (m)							
FV 160	FV 160T	1,5	1,1	2,5	2,3	12,2	10,9	8,4	5,6	4,1	2,6		
FV 210	FV 210T	2	1,5	2,8	2,7	13,7	12,6	9,9	7,0	5,4	3,8	3,1	
-	FV 310T	3	2,2	-	3,3	15,5	14,4	11,6	8,8	7,1	5,4	4,5	3,8

FV

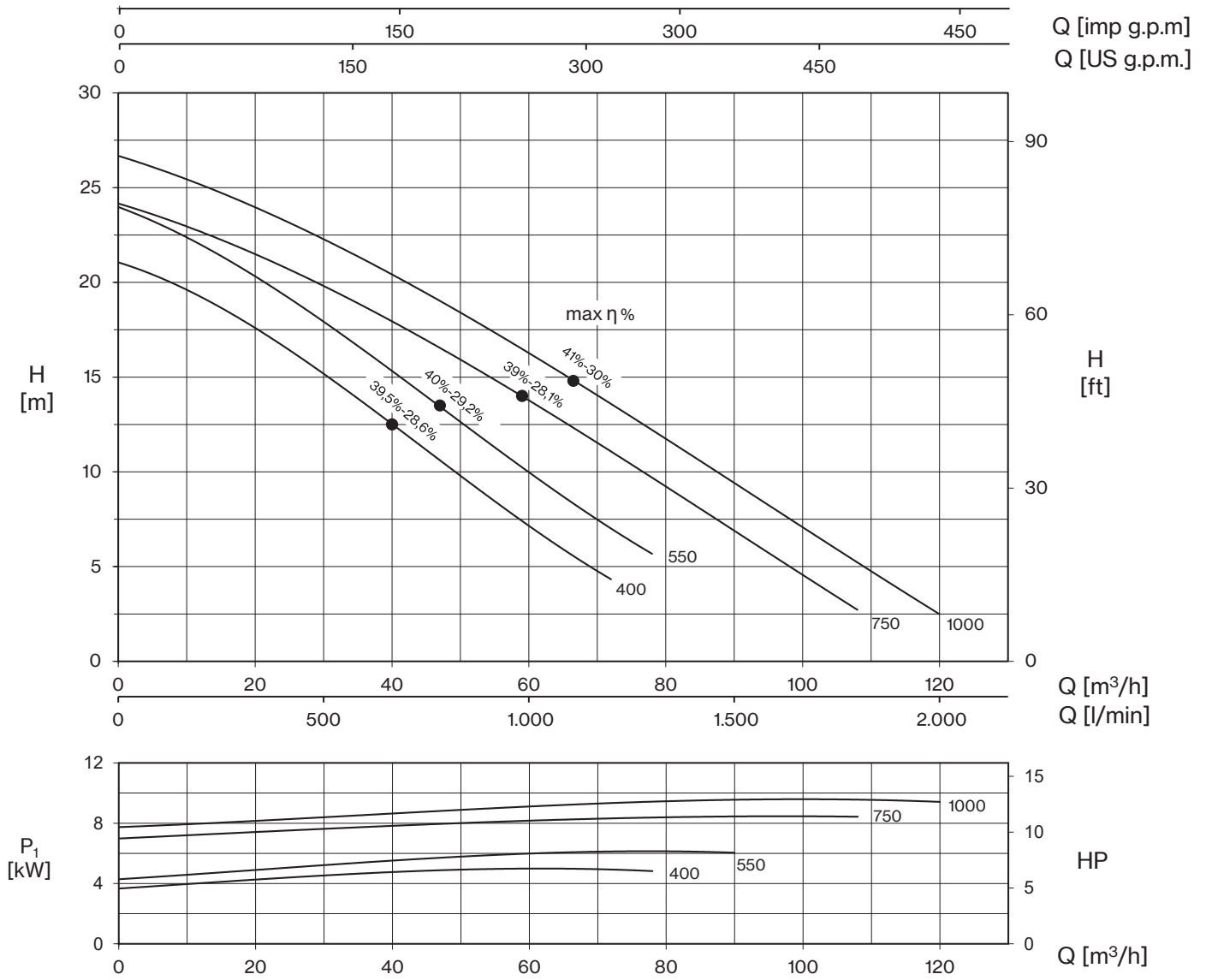

TYPE	AMPERE			
	3~ 230V 50 Hz (*)	3~ 400V 50 Hz	230/400 V 50 Hz λ / Δ (*)	400/690 V 50 Hz λ / Δ
FV 400T	14,1	8,1	-	-
FV 550T	18,1	10,4	-	-
FV 750T	-	14,4	25	14,4
FV 1000T	-	16,4	28,5	16,4

+ max η %

max hydraulic efficiency and respective total efficiency

(*) no standard execution

TYPE	P2		P1 (kW)	Q (m³/h - l/min)																
				0	12	24	36	42	48	51	54	60	72	78	84	90	96	108	114	120
	HP	kW	3~	0	200	400	600	700	800	850	900	1000	1200	1300	1400	1500	1600	1800	1900	2000
FV 400T	4	3	4,9	21,0	19,4	16,6	13,5	12,0	10,4	9,6	8,8	7,2	4,3	2,8						
FV 550T	5,5	4	6,1	23,9	22,2	19,3	16,3	14,8	13,2	12,4	11,6	10	7,1	5,6	4,1	2,6				
FV 750T	7,5	5,5	8,5	24,2	22,7	20,7	18,7	17,6	16,4	15,8	15,2	13,9	11,1	9,7	8,2	6,8	5,4	2,8		
FV 1000T	10	7,5	9,6	26,7	25,2	23,2	21,2	20,0	18,8	18,2	17,6	16,3	13,7	12,3	10,8	9,4	8,0	5,1	3,8	2,6

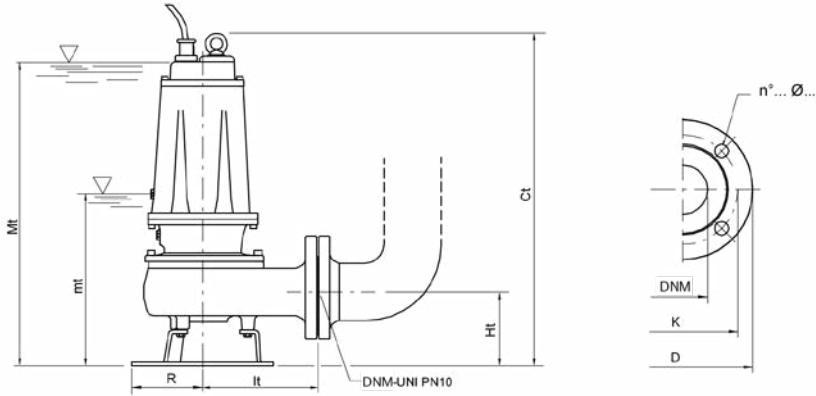

mt: minimum working level
 Mt: minimum submersion level for continuous duty

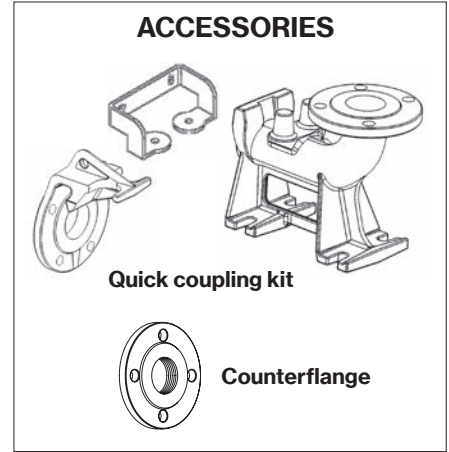

TYPE	DIMENSIONS (mm)							Kg
	Ct	Ht	R	It	mt	Mt	DNM	
FV 160T	551	123	117	191	243	513	65	39,5
FV 160 - FV 210T	551	123	117	191	243	513	65	40,5
FV 210 - FV 310T	551	123	117	191	243	513	65	41,5
FV 400T	645	148	160	210	285	600	80	68
FV 550T	645	148	160	210	285	600	80	71
FV 750T	725	178	180	232	358	670	80	90
FV 1000T	725	178	180	232	358	670	80	92,5

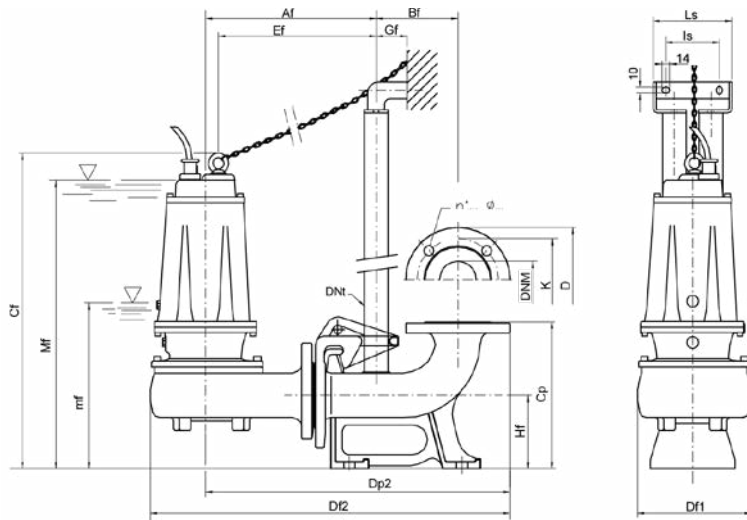

mf: minimum working level
 Mf: minimum submersion level for continuous duty

Flange UNI PN 10 (mm)			
DNM	K	D	n°... Ø...
65	145	185	4... 18...
80	160	200	8... 18...

TYPE	DIMENSIONS (mm)																		
	Af	Bf	Cf	Cp	Df1	Df2	Dp2	DNt	Ef	Gf	Hf	I1	I2	Is	Ls	mf	Mf	DNM	
FV 160T/P	303	145	559	260	200	639	541	1" 1/4	280	55	130	200	100	95	140	251	521	65	
FV 160 - FV 210T/P	303	145	559	260	200	639	541	1" 1/4	280	55	130	200	100	95	140	251	521	65	
FV 210 - FV 310T/P	303	145	559	260	200	639	541	1" 1/4	280	55	130	200	100	95	140	251	521	65	
FV 400T/P	350	165	690	340	220	720	615	2"	319	85	190	250	140	130	180	327	642	80	
FV 550T/P	350	165	690	340	220	720	615	2"	319	85	190	250	140	130	180	327	642	80	
FV 750T/P	370	165	745	340	235	750	638	2"	338	85	190	250	140	130	180	380	690	80	
FV 1000T/P	370	165	745	340	235	750	638	2"	338	85	190	250	140	130	180	380	690	80	

TYPE	PROTECTION		1 PUMP CONTROL PANEL			2 PUMPS CONTROL PANEL		
	1- 230V	3- 400V	1- 230V	3- 400V	400/690 V	1- 230V	3- 400V	400/690 V
FV 160	PMC 15/35-15	PT 20-30-40/4.3-6.8	EQSM + 35µF	EQSMT 10		EQ2SM + 35µF	EQ2SMT 10	
FV 210	PMC 20/50-18	PT 20-30-40/4.3-6.8	EQSM + 50µF	EQSMT 10		EQ2SM + 50µF	EQ2SMT 10	
FV 310T		PT 40-50/5.7-9.1		EQSMT 10			EQ2SMT 10	
FV 400T		PT 55-75/8.6-13.5		EQSMT 10			EQ2SMT 10	
FV 550T		PT 55-75/8.6-13.5		EQSMT 10			EQ2SMT 10	
FV 750T		PT 100/12.5-16.5		EQSMT 10	QST 7		EQ2SMT 10	Q2ST 7
FV 1000T		PT 125-150/16-21		EQSMT 10	QST 10		EQ2SMT 10	Q2ST 10